



Paper – II

Electronic Science

Booklet Code

A

TEST BOOKLET NO.

Subject Code : 1 4

Roll No. : [] [] [] [] [] [] [] [] [] []

(Figures as per admission card)

Roll No. (in words) : _____

OMR Sheet No. : [] [] [] [] [] [] [] []

Name and Signature of Invigilator/s

Signature : _____

Name : _____

Time : 2 Hours

Maximum Marks : 200

Number of Pages in this Booklet : 16

Number of Questions in this Booklet : 100

Instructions for the Candidates

- Write your roll number in the space provided on the top of this page.
- This paper consists of hundred (100) multiple-choice type of questions.
- At the commencement of examination, the test booklet will be given to you. In the first 5 minutes, you are requested **to open the booklet and compulsorily examine it as below** :
 - To have access to the Test Booklet, tear off the paper seal on the edge of the cover page. Do not accept a booklet without sticker seal or open booklet.
 - Tally the number of pages and number of questions in the booklet with the information printed on the cover page. Faulty booklets due to pages/questions missing or duplicate or not in serial order or any other discrepancy should be got replaced immediately by a correct booklet from the invigilator within the period of 5 minutes. Afterwards, neither the Test Booklet will be replaced nor any extra time will be given.**
 - After the verification is over, the Test Booklet Number should be entered in the OMR Sheet and the OMR Sheet Number should be entered on this Test Booklet.
- Each item has four alternative responses marked (A), (B), (C) and (D). You have to darken the circle as indicated below on the correct response against each item.
Example : (A) (B) (C) (D)
 where (C) is the correct response.
- Your responses to the questions are to be indicated in the **OMR Sheet kept inside this Booklet**. If you mark at any place other than in the circles, the OMR Sheet will not be evaluated.
- Read the instructions given in OMR Sheet carefully. Fill the Booklet Code of Paper – II in OMR Sheet **Compulsorily**.
- Rough Work is to be done in the end of this booklet.
- If you write your name or put any mark on any part of the OMR Answer Sheet, except for the space provided for the relevant entries, which may disclose your identity, you will render yourself liable to disqualification.
- You have to return the OMR Answer Sheet to the invigilators at the end of the examination compulsorily and must NOT carry it with you outside the Examination Hall.
- You can take away test booklet and carbon copy of OMR Answer Sheet after the examination.
- Use only Blue/Black Ball point pen.**
- Use of any calculator, electronic gadgets or log table, etc. is prohibited.**
- There is no negative mark for incorrect answer.**



ELECTRONIC SCIENCE
Paper – II

1. Find the current I_L and the voltage V_C of the below given network.

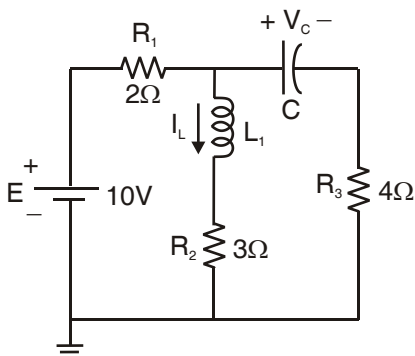

- (A) 6A, 2V
(B) 6A, 6V
(C) 2A, 6V
(D) 2A, 2V

2. Using superposition theorem, determine the current through the 4 Ω resistor of the below figure.

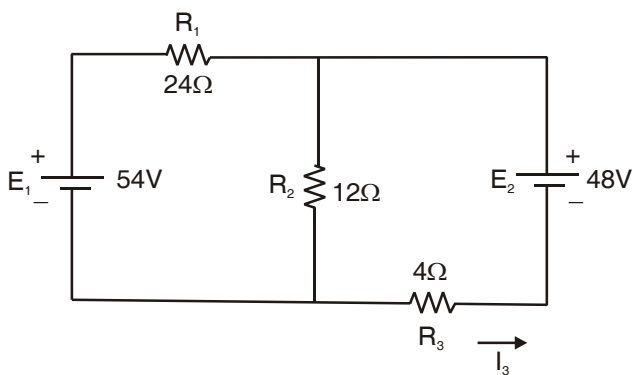

- (A) 2.5 A
(B) 8.5 A
(C) 6.5 A
(D) 12.5 A

3. For the JFET in the below figure, $V_{GS(off)} = -4V$ and $I_{DSS} = 12 \text{ mA}$. Determine the minimum value of V_{DD} required to put the device in the constant-current region of operation.

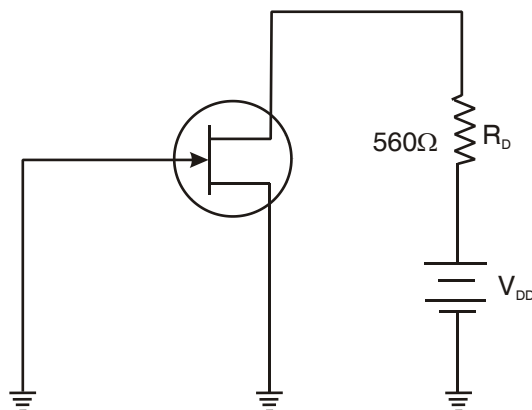

- (A) 9.72 V
(B) 11.72 V
(C) 10.72 V
(D) 15.72 V

4. For the common base circuit shown in figure, what will be the I_C and V_{CB} ? Assume the transistor to be of silicon.

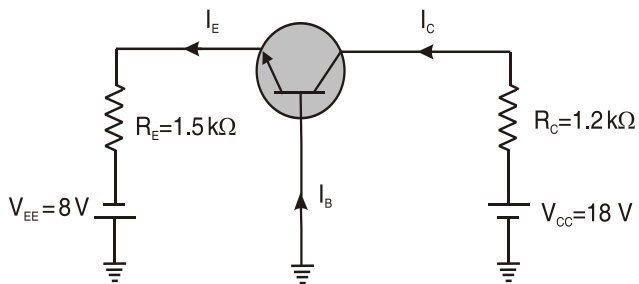

- (A) 4.87 mA and 12.16 V
(B) 10.11 mA and 15.5 V
(C) 13.72 mA and 4.87 V
(D) 12.16 mA and 4.87 V



5. For the network given in the figure what will be r_e ?

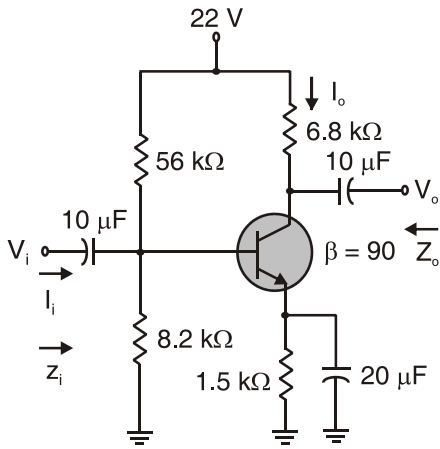

- (A) 18.44 Ω (B) 19.44 Ω
(C) 20.44 Ω (D) 21.44 Ω

6. Why are alkali metals most suited as photo-sensitive metals ?

- (A) High frequency
(B) Zero rest mass
(C) High work function
(D) Low work function

7. Match List – I and List – II and select the correct answer using the codes given below :

List – I

- a. QPSK
b. Hamming code
c. Superheterodyne
d. Frequency modulation

List – II

- i. Deviation
ii. I.F.
iii. Error correction
iv. 90°

Codes :

a b c d

- (A) iv i ii iii
(B) iv ii iii i
(C) ii iii iv i
(D) iv iii ii i

8. In a normal ECG waveform which wave has the maximum amplitude ?

- (A) P wave (B) R wave
(C) Q wave (D) T wave

9. Anderson's bridge is a modification of

- (A) Maxwell-Wien bridge
(B) Hay's bridge
(C) Schering bridge
(D) Owen bridge

10. Which type of transducer is commonly used for invasive blood pressure measurement ?

- (A) Capacitive (B) Rheostatic
(C) Piezoelectric (D) Potentiometric

11. What will be the number of flip-flop required to construct a MOD-10 Johnson counter ?

- (A) 6 (B) 8
(C) 10 (D) 5

12. In a frequency counter, what happens at high frequencies when the sampling intervals is too long ?

- (A) The counter overflows
(B) The measurement is less precise
(C) The counter undercounts the frequency
(D) The counter works fine



13. In the below diagram, what does an arrow between the circles indicates ?

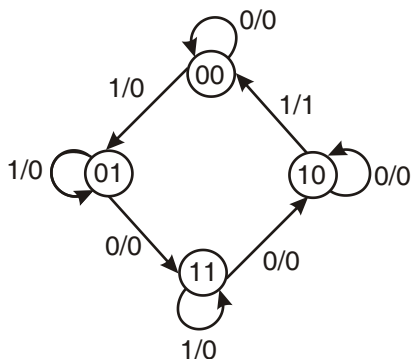

- (A) Next state
- (B) Present state
- (C) Don't care condition
- (D) State transition

14. Which type of PLD should be used to program basic logic functions ?

- (A) PAL
- (B) PLA
- (C) SLD
- (D) CPLD

15. For the binary ripple counter given below, what will be the modulus and frequency of the flip-flop Q3 output ?

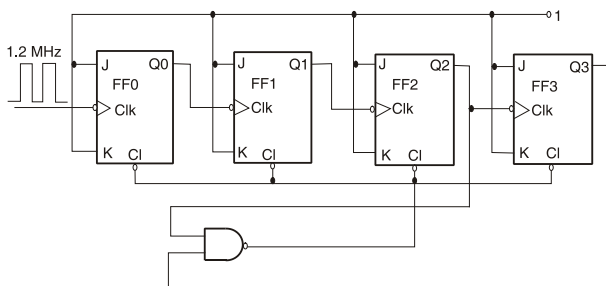

- (A) 12, 100 kHz
- (B) 10, 100 kHz
- (C) 10, 10 kHz
- (D) 8, 100 kHz

16. A multimode graded index fiber, exhibits total pulse broadening of $0.1 \mu\text{s}$ over a distance of 15 km. Following data is estimated by using the concept of that there is no inter-symbol interference :

- a. The maximum possible Bandwidth is 5 MHz
- b. The dispersion per unit length is 6.67 ns/km
- c. The maximum possible B.W. is 10 MHz
- d. The dispersion/unit length is 3.37 ns/km

Which is the correct option ?

- (A) a and d
- (B) b and c
- (C) c and d
- (D) a and b

17. What is the fourth harmonic of a fundamental frequency of 400 Hz ?

- (A) 1.6 kHz
- (B) 100 Hz
- (C) 4 kHz
- (D) 4 Hz

18. Forward breakover voltage in a SCR defined as

- (A) Voltage above which the SCR enters the conduction region
- (B) Voltage below which the SCR enters the conduction region
- (C) Voltage above which the SCR enters the breakdown region
- (D) Voltage below which the SCR enters the breakdown region



19. The turn-off time of an SCR can be reduced by
- Quick withdrawal of the gate voltage.
 - Reducing life-time by doping with gold.
 - Applying a negative voltage pulse to the gate.

Which one of the following is correct ?

- a, b and c are correct
 - a and b are correct
 - a and c are correct
 - b and c are correct
20. DIAC can be turned ON using
- Gate voltage
 - Forward voltage
 - Breakover voltage
 - Reverse voltage
21. At which state the phase-locked loop tracks any change in input frequency ?
- Capture state
 - Free running state
 - Phase locked state
 - Steady state
22. In CMOS monostable circuit, element which is used to prevent input voltage signal from rising above supply voltage is
- Diode
 - Capacitor
 - Inductor
 - Resistor
23. In an amplifier with gain of -1000 and feedback of $b = -0.1$ has a gain change of 20% due to temperature, calculate the change in gain of the feedback amplifier.
- 20%
 - 0.2%
 - 2%
 - 40%

24. What is the frequency of a signal if the time taken to complete one cycle is 0.2 seconds ?

- 20 Hz
- 5 Hz
- 4 Hz
- 0.5 Hz

25. The Boolean expression $Y = AB + (A + B) (\bar{A} + B)$ may be simplified as

- $Y = B$
- $Y = \bar{A}$
- $Y = \bar{B}$
- $Y = A$

26. The following item consist of two statements, one labelled as "Assertion (A)" and the other labelled as "Reason (R)".

Assertion (A) : Architecturally 8086 μp is totally different from its predecessor 8085 μp but functionally it is downward compatible with 8085.

Reason (R) : The segmented architecture was introduced in 8086 μp to keep compatibility with 8085 μp .

Select your answer using the codes given below and mark your answer accordingly.

Codes :

- Both (A) and (R) are true and (R) is the correct explanation of (A)
- Both (A) and (R) are true, but (R) is not the correct explanation of (A)
- (A) is true, but (R) is false
- (A) is false, but (R) is true



27. Which of these is non-operational attribute of embedded system ?
- (A) Response
 - (B) Throughput
 - (C) Security
 - (D) Portability
28. Overmodulation occurs when signal amplitude is _____ the carrier amplitude.
- (A) Equal to
 - (B) Greater than
 - (C) Smaller than
 - (D) None of these
29. In a radio receiver, noise is generally developed at
- (A) IF stage
 - (B) Receiving antenna
 - (C) RF stage
 - (D) Audio stage
30. As the modulation level is increased carrier power
- (A) Remains same
 - (B) Is decreased
 - (C) Is increased
 - (D) None of these
31. For an open loop system, control action
- (A) Depends on the output
 - (B) Does not depends on the output
 - (C) Depends on the input
 - (D) Independent of the input
32. As per the Nyquist stability criterion, the position of all zeros of $q(s)$ corresponding to s-plane should lies at the
- (A) Center
 - (B) Left half
 - (C) Right half
 - (D) Anywhere
33. What technique provide speed control over the base speed for DC motor ?
- (A) Supply voltage control method
 - (B) Field control method
 - (C) Supply current control method
 - (D) Resistance control method
34. Routh's array for a system is given below :
- | | | | |
|-------|----|---|---|
| S^4 | 1 | 3 | 5 |
| S^3 | 1 | 2 | 9 |
| S^2 | 1 | 5 | |
| S^1 | -3 | | |
| S^0 | 5 | | |
- The system is
- (A) Stable
 - (B) Unstable
 - (C) Marginally stable
 - (D) Conditionally stable
35. The working principle for Switched Mode Power Supply (SMPS) is based on
- (A) Integrated control
 - (B) Phase control
 - (C) Chopper control
 - (D) Frequency control



36. When a circuit is represented by equivalent Thevenin's circuit and Norton's circuit ?

- (A) Norton resistance < Thevenin resistance
- (B) Norton resistance = Thevenin resistance
- (C) Norton resistance > Thevenin resistance
- (D) Do not have any relation

37. The voltage at Node 1 in the figure below is

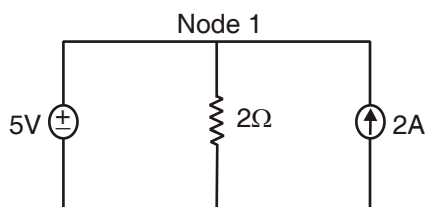

- (A) 2.5 V
- (B) 3 V
- (C) 2 V
- (D) 5 V

38. In an A.C. circuit always

- (A) Reactive power is more than actual power
- (B) Apparent power is more than actual power
- (C) Reactive power is more than apparent power
- (D) Actual power is more than reactive power

39. What will be the Laplace transform of $t^2 e^t \sin 4t$?

- (A) $\frac{8(3s^2 - 6s - 13)}{(s^2 - 2s + 17)^3}$
- (B) $\frac{8(3s^2 - 6s - 17)}{(s^2 - 2s + 17)^4}$
- (C) $\frac{8(3s^3 - 6s - 13)}{(s^2 - 2s + 17)^3}$
- (D) $\frac{8(3s^2 - s - 13)}{(s^2 - 2s + 17)^3}$

40. Consider the following statements regarding z-transform :

- a. The z-transform replaces the Laplace transform for sampled-data system.
- b. The z-transform replaces the Laplace transform for continuous-data system.
- c. The z-transform provides direct parallels to the s-plane analysis of transients, steady state errors, stability etc.
- d. We cannot map points on s-plane to points on z-plane.

Which of the above statements are correct ?

- (A) a and c only
- (B) a and d only
- (C) b, c and d only
- (D) a, b and d only



41. The wavelength of radiation emitted by an LED made up of a semiconducting material with band gap energy 2.8 eV is
(A) 4430.8 Å (B) 2.8 Å
(C) 6130.6 Å (D) 5548.8 Å
42. A ruby laser has a crystal of length 3 cm with a refractive index of 1.60, wavelength 0.43 μm has number of longitudinal modes
(A) 2.9×10^5 (B) 2.2×10^5
(C) 3.0×10^5 (D) 4.0×10^5
43. The pumping source in Nd -YAG laser is
(A) Mechanical (B) Electrical
(C) Optical (D) Chemical
44. Which of the following scheme does not produce lasing action ?
(A) Two level
(B) Three level
(C) Four level
(D) Five level
45. How does refractive index vary in step index fibre ?
(A) Radially (B) Longitudinally
(C) Tangentially (D) Transversally
46. The sensitive region of a p-n junction particle detector is the
(A) p-region
(B) n-region
(C) p, n and Depletion region
(D) Depletion region
47. Which of the following photoelectric devices is most suitable for digital applications ?
(A) Photo-voltaic cell
(B) Photo-emissive
(C) Photo-diode
(D) Photo-transistor
48. An electron is in the ground state of a hydrogen atom. The probability that it is within the Bohr radius is approximately equal to
(A) 0.60 (B) 0.90
(C) 0.16 (D) 0.32
49. A transistor is said to be operating in the cut-off region if
(A) Emitter junction is forward biased and collector junction is forward biased
(B) Emitter junction is reverse biased and collector junction is reverse biased
(C) Emitter junction is reverse biased and collector junction is forward biased
(D) Emitter junction is forward biased and collector junction is reverse biased
50. _____ transistor is most suitable for high-frequency circuits.
(A) Hermetically sealed
(B) Grown-diffusion
(C) Rate-grown
(D) Alloy
51. In an 8085 microprocessor, the number of address lines required to access a 16 K byte memory bank is
(A) 15 (B) 14
(C) 13 (D) 5



52. The clock frequency of an 8085 microprocessor is 5 MHz, if the time required to execute an instruction is $1.4 \mu\text{s}$, then the number of T-states needed for executing the instruction is
(A) 2 (B) 4
(C) 6 (D) 7
53. An 8 K byte ROM with an active chip select input ($\overline{\text{CS}}$) is to be used in an 8085-microprocessor based system. The ROM should occupy the address range 1000H to 2FFFH. The address lines are designated as A15 to A0, where A15 is the most significant address bit. Which one of the following expression will generate the correct ($\overline{\text{CS}}$) signal for this ROM ?
(A) $A_{15} + A_{14} + (A_{13} \cdot A_{12} + \overline{A_{13}} \cdot \overline{A_{12}})$
(B) $A_{15} \cdot A_{14} \cdot (A_{13} + A_{12})$
(C) $\overline{A_{13}} + \overline{A_{14}} + (A_{13} \cdot A_{12} + \overline{A_{13}} \cdot \overline{A_{12}})$
(D) $\overline{A_{15}} + \overline{A_{14}} + A_{13} \cdot A_{12}$
54. What is the size of address bus in 8086 microprocessor ?
(A) 20 bit
(B) 10 bit
(C) 12 bit
(D) 16 bit
55. Consider the following instruction:
EI
MVI A, 08H
SIM
It means :
(A) Disable all interrupts
(B) Enable all interrupts
(C) Disable RST 7.5 and 6.5
(D) Enable TRS 7.5 and 6.5
56. The relationship between minimum wavelength of X-ray generated from a target metal and the applied voltage is given by
(A) Bragg's Equation
(B) Moseley Equation
(C) Illkovic Equation
(D) Duane-Hunt Equation
57. The detector in X-Ray diffraction that detects the visible radiation is
(A) Scintillation Counter
(B) Proportional Counter
(C) Golay Detector
(D) Silicon Diode
58. _____ is a PVD technique in which the bulk material is released into the vacuum by bombardment from an ion source.
(A) Spreading
(B) Splashing
(C) Splattering
(D) Sputtering
59. _____ involves depositing successive layers of different substances to produce layered, crystalline films.
(A) Atomic layer chemical vapor deposition
(B) Thermal chemical vapor deposition
(C) Low-pressure chemical vapor deposition
(D) Plasma enhanced chemical vapor deposition



60. The most significant advantage of CCD is
(A) Low Density
(B) High Density
(C) Low Gain
(D) High Gain
61. Every frequency has _____ orthogonal functions.
(A) 6 (B) 1
(C) 4 (D) 2
62. Wavelength and antenna size are related as
(A) Wavelength /4
(B) Wavelength /2
(C) Twice wavelength
(D) None of the above
63. Bandwidth of BPSK is _____ BFSK bandwidth.
(A) Equal to (B) Higher than
(C) Lower than (D) Twice
64. A 1 MHz carrier is amplitude modulated by an audio signal with frequencies in the range 500 Hz, 1 kHz, 3 kHz and 5 kHz. What is the output bandwidth ?
(A) 8 kHz (B) 1 kHz
(C) 2 kHz (D) 10 kHz
65. In a ruby laser, colour of laser light is due to
(A) Xenon (B) Aluminium
(C) Chromium (D) Oxygen
66. What will be the cutoff frequency of a first-order low-pass filter for $R_1 = 1.2 \text{ k}\Omega$ and $C_1 = 0.02 \text{ }\mu\text{F}$?
(A) 10.52 kHz
(B) 6.63 kHz
(C) 35.91 kHz
(D) 40.11 kHz
67. What will be the output voltage of an op-amp for input of $V_{i1} = 150 \text{ }\mu\text{V}$, $V_{i2} = 140 \text{ }\mu\text{V}$? The amplifier has a differential gain of $A_d = 4000$ and the value of $\text{CMRR} = 100$.
(A) 10.5 mV (B) 20.5 mV
(C) 30.2 mV (D) 45.8 mV
68. For a transformer output of 15 V and a filter capacitor of $150 \text{ }\mu\text{F}$, what will be the minimum input voltage when connected to a load drawing 400 mA ?
(A) 8.35 V (B) 12.50 V
(C) 19.20 V (D) 49.85 V
69. Which of the following is not a voltage to frequency converter ?
(A) BC541
(B) LM2917
(C) LM555
(D) KA331
70. The Q-point of a voltage amplifier is selected in the middle of the active region because
a. In this case it requires a small dc voltage
b. The operating point becomes stable
c. It gives distortionless output
d. It is suitable for small input signals without distorted output
Which of the following is correct ?
(A) b and d
(B) c and d
(C) a and d
(D) b and a
71. In applications where _____ input resistance is needed, the JFET is preferred to the bipolar transistor.
(A) Low (B) Very low
(C) Zero (D) High



72. The depletion N-channel MOSFET
- (A) Can be operated as a JFET with zero gate voltage
 - (B) Can be operated as an enhancement MOSFET by applying +ve bias to gate
 - (C) Can be operated as an enhancement MOSFET by applying –ve bias to gate
 - (D) Cannot be operated as an enhancement MOSFET
73. Which one of the following statements is true ?
- (A) Current flows in a capacitor circuit only while ions are permitted to flow through the dielectric material
 - (B) Current flows in a capacitor circuit only while the charge on the plates is large enough to force the dielectric to conduct electrons
 - (C) Current can flow in a capacitor circuit, but not through the dielectric material itself
 - (D) Power returned to the circuit is always greater than the power absorbed

74. Consider the following logic families :

- | | |
|--------|--------|
| 1. MOS | 2. TTL |
| 3. RTL | 4. ECL |

The correct sequence of the logic families in the order of their increasing noise margin is

- (A) 3, 4, 1, 2
- (B) 3, 4, 2, 1
- (C) 4, 3, 2, 1
- (D) 4, 3, 1, 2

75. The following item consist of two statements, one labelled as “Assertion (A)” and the other labelled as the “Reason (R)”.

Assertion (A) : The intrinsic Fermi level of a semiconductor lies exactly at the middle of the energy gap.

Reason (R) : The densities of the available state in valence and conduction bands of a semiconductor are equal.

Select your answer using the code given below and mark your answer accordingly.

Codes :

- (A) Both (A) and (R) are true and (R) is the correct explanation of (A)
 - (B) Both (A) and (R) are true, but (R) is not the correct explanation of (A)
 - (C) (A) is true, but (R) is false
 - (D) (A) is false, but (R) is true
76. What is the function of the WR pin ?
- (A) Its active high input used to inform ADC0804 to the start of conversion
 - (B) Its active low input used to inform ADC0804 to the start of conversion
 - (C) Its active low input used to inform ADC0804 to the end of conversion
 - (D) Its active high input used to inform ADC0804 to the end of conversion

77. What is the function of the TMOD register ?

- (A) TMOD register is used to set various operation modes of timer/counter
- (B) TMOD register is used to load the count of the timer
- (C) Is the destination or the final register where the results is obtained after the operation of the timer
- (D) Is used to interrupt the timer



78. Why is CHMOS technology preferred over HMOS technology for designing the devices of MCS-51 family ?
- (A) Due to higher speed
 - (B) Due to higher noise immunity
 - (C) Due to lower power consumption
 - (D) All of the above
79. Which of the following condition takes place when the Microcontroller 8051 is reset ?
- (A) SP=08H, P1=00H, RS0=1, RS1=1
 - (B) SP=07H, P1=00H, RS0=0, RS1= 0
 - (C) SP=08H, P1=FFH, RS0=0, RS1=0
 - (D) SP=07H, P1=FFH, RS0=0, RS1=0
80. Which of the following is a 16-bit register in 8085 processor ?
- i. Stack pointer
 - ii. Program counter
 - iii. Accumulator
- (A) i and ii
 - (B) ii and iii
 - (C) ii only
 - (D) i only
81. Quarter-wave damping for PID may be described as
- (A) a condition of good control where PV approaches SP without overshoot
 - (B) a condition of poor control where oscillations continue at constant amplitude
 - (C) a condition of poor control where the transmitter is damped by 25%
 - (D) a condition of good control where oscillations quickly subside
82. A Hall effect element is used for the measurement of magnetic field of 0.8 Wb/m^2 . The thickness of the element is 2.5 mm and is of bismuth material. If the current passed through the element is 4 A and Hall Coefficient is 5×10^{-7} then the Hall voltage developed will be
- (A) $1.4 \times 10^{-4} \text{ V}$
 - (B) $6.4 \times 10^{-4} \text{ V}$
 - (C) $2.0 \times 10^{-4} \text{ V}$
 - (D) $3.2 \times 10^{-4} \text{ V}$
83. To measure waveform of a signal, the horizontal plates of a CRO are supplied with
- (A) Sine wave (B) Cosine wave
 - (C) Step wave (D) Sawtooth wave



84. Match the following list :

List – I	List – II
a. PCON	i. contains status information
b. TMOD	ii. timer/counter control register
c. TCON	iii. idle bit, power down bit
d. PSW	iv. timer/counter modes of operation

Codes :

	a	b	c	d
(A)	i	iii	iv	ii
(B)	iii	iv	ii	i
(C)	ii	i	iii	iv
(D)	iv	ii	i	iii

85. The following item consist of two statements, one labelled as “Assertion (A)” and the other labelled as the “Reason (R)”.

Assertion (A): Piezoelectric transducers are not suitable for ultra-low frequency vibration measurement.

Reason (R): Piezoelectric materials have a high dielectric constant.

Select your answer using the code given below and mark your answer accordingly.

Codes :

- (A) Both (A) and (R) are true and (R) is the correct explanation of (A)
- (B) Both (A) and (R) are true, but (R) is not the correct explanation of (A)
- (C) (A) is true, but (R) is false
- (D) (A) is false, but (R) is true

86. For a unity feedback control system with the forward path transfer function

$$G(s) = \frac{K}{s(s+1)} .$$

The peak resonant magnitude M_r of the closed-loop frequency response is 2. The corresponding value of the gain K will be

- (A) 14.9
- (B) 21
- (C) 28
- (D) 55

87. Find z-transform of a signal $\sin(n\omega_0)u(n)$

(A) $\frac{1 - z^{-1} \cos(\omega_0)}{1 - 2z^{-1} \cos(\omega_0) + z^{-2}} \quad |z| > 1$

(B) $\frac{1 - z^{-1} \cos(\omega_0)}{1 + 2z^{-1} \cos(\omega_0) + z^{-2}} \quad |z| > 1$

(C) $\frac{z^{-1} \sin(\omega_0)}{1 - 2z^{-1} \cos(\omega_0) + z^{-2}} \quad |z| > 1$

(D) $\frac{z^{-1} \sin(\omega_0)}{1 + 2z^{-1} \cos(\omega_0) + z^{-2}} \quad |z| > 1$

88. The system given by

$$y(n) = x(n) + \frac{1}{x(n-1)} \text{ is}$$

- (A) Causal
- (B) Linear
- (C) Both (A) and (B)
- (D) Non causal



89. For maximum transfer of power, internal resistance of the source should be
- (A) Less than the load resistance
(B) Equal to the load resistance
(C) Greater than the load resistance
(D) Zero
90. In Unit impulse function
- (A) Pulse width is zero
(B) Height of the pulse goes to unity
(C) Area of pulse is infinity
(D) Pulse width is unity
91. The data sheet of a quad two-input NAND gate specifies the following parameters : $I_{CCH}(\text{max}) = 1.6 \text{ mA}$, $I_{CCL}(\text{max}) = 4.4 \text{ mA}$ and a supply voltage range of 5V. What will be the average power dissipation of a single NAND gate ?
- (A) 5 mW (B) 3.5 mW
(C) 8 mW (D) 3.75 mW
92. What will be the size of PROM required for implementing the logic circuit of a single-digit BCD adder/subtractor with a control input for selection of operation ?
- (A) $1 \text{ K} \times 5$ (B) $512 \text{ K} \times 2$
(C) 256×8 (D) $256 \text{ K} \times 8$

93. Which type of CPLD packaging can provide maximum number of pins on the package due to small size of the pins ?
- (A) PLCC (B) QFP
(C) PGA (D) BGA
94. Monostable multivibrator given in the below circuit. The trigger terminal (pin 2 of the IC) is driven by a symmetrical pulsed waveform of 10 kHz. What will be the frequency and duty cycle of the output waveform ?

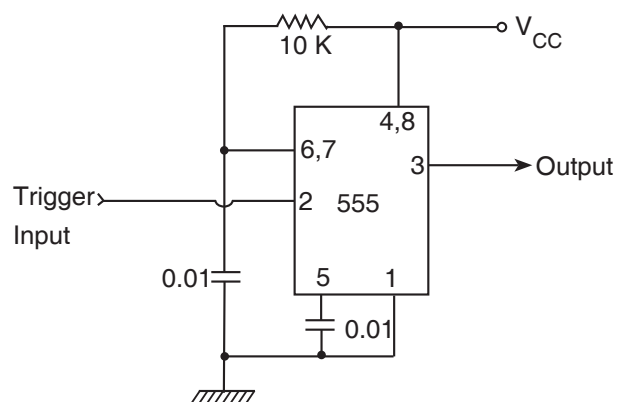

- (A) 5 kHz, 0.55
(B) 10 kHz, 0.55
(C) 20 kHz, 0.75
(D) 5 kHz, 0.80



95. What will be the modulus of the presetable counter, if the counter were initially in the 0110 state, what would be the state of the counter immediately after the eighth clock pulse ?

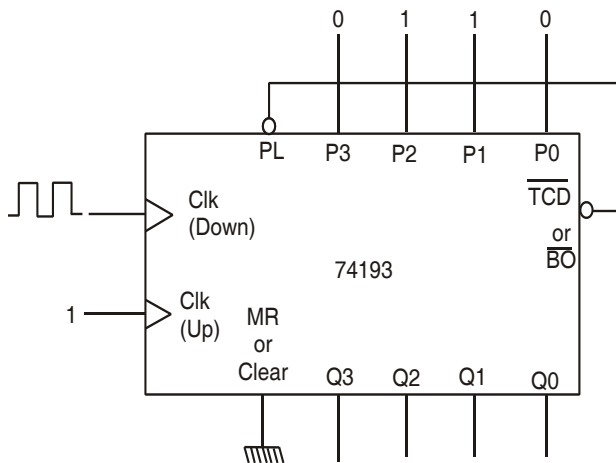

- (A) 8, 1010
(B) 8, 1100
(C) 6, 0100
(D) 10, 0110
96. Which of the following is used to obtain silicon crystal structure while fabricating Integrating Circuits ?
- (A) Oxidation
(B) Epitaxial growth
(C) Photolithography
(D) Silicon wafer preparations

97. In Czochralski crystal growth process, the materials are heated up to
- (A) 950°C
(B) 1000°C
(C) 1420°C
(D) 1200°C
98. The process involved in photolithography is
- (A) Making of a photographic mask only
(B) Photo etching
(C) Doping
(D) Both photo etching and making of photographic mask
99. Which one of the following is not the strengthening mechanism ?
- (A) Alloying
(B) Heat Treatment
(C) Strain Hardening
(D) Metalizing
100. VLSI technology uses _____ to form Integrated Circuit.
- (A) Transistors (B) Switches
(C) Diodes (D) Buffers



Total Number of Pages : 16

Space for Rough Work

