

SECTION-A

1. The straight lines l_1 and l_2 pass through the origin and trisect the line segment of the line $L : 9x + 5y = 45$ between the axes. If m_1 and m_2 are the slopes of the lines l_1 and l_2 , then the point of intersection of the line $y = (m_1 + m_2)x$ with L lies on.

- (1) $6x + y = 10$ (2) $6x - y = 15$ (3) $y - 2x = 5$ (4) $y - x = 5$

Sol. (4)

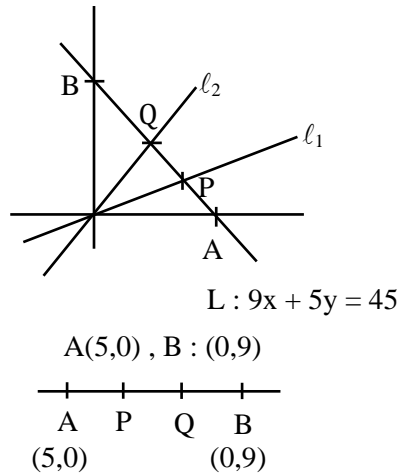

$$\rightarrow P_x = \frac{2 \times 5 + 1 \times 0}{1 + 2} = \frac{10}{3}$$

$$P_y = \frac{0 \times 2 + 9 \times 1}{1 + 2} = 3$$

$$P : \left(\frac{10}{3}, 3 \right)$$

$$\text{Similarly } \rightarrow Q_x = \frac{1 \times 5 + 2 \times 0}{1 + 2} = \frac{5}{3}$$

$$Q_y = \frac{1 \times 0 + 2 \times 9}{1 + 2} = 6$$

$$Q : \left(\frac{5}{3}, 6 \right)$$

$$\text{Now } m_1 = \frac{3 - 0}{\frac{10}{3} - 0} = \frac{9}{10}$$

$$m_2 = \frac{6 - 0}{\frac{5}{3} - 0} = \frac{18}{5}$$

$$\text{Now } L_1 : y (m_1 + m_2)x \Rightarrow y = \left(\frac{9}{2} \right) x \Rightarrow 9x = 2y \dots (2)$$

$$\begin{array}{r} \text{from (1) \& (2)} \quad 9x + 5y = 45 \\ \quad \quad \quad 9x - 2y = 0 \\ \hline \quad \quad \quad - \quad + \quad - \end{array}$$

$$7y = 45 \Rightarrow y = \frac{45}{7}$$

$$\Rightarrow x = \frac{10}{7}$$

which satisfy $y - x = 5$ Ans. 4

Sol. (3)

$$s_n = 5 + 11 + 19 + 29 + 41 + \dots + T_n$$
$$S_n = \frac{5 + 11 + 19 + 29 + \dots + T_{n-1} + T_n}{1}$$
$$0 = 5 + \left\{ \underbrace{6 + 8 + 10 + 12 + \dots}_{(n-1)\text{ terms}} \right\} - T_n$$
$$T_n = 5 + \frac{(n-1)}{2} [2 \cdot 6 + (n-2) \cdot 2]$$
$$T_n = 5 + (n-1)(n+4) = 5 + n^2 + 3n - 4 = n^2 + 3n + 1$$

Now $S_{20} = \sum_{n=1}^{20} T_n = \sum_{n=1}^{20} n^2 + 3n + 1$

$$S_{20} = \frac{20 \cdot 21 \cdot 41}{6} + \frac{3 \cdot 20 \cdot 21}{2} + 20$$
$$S_{20} = 2870 + 630 + 20$$
$$S_{20} = 3520$$

5. A pair of dice is thrown 5 times. For each throw, a total of 5 is considered a success. If probability of at least 4 successes is $\frac{k}{3^{11}}$, then k is equal to :

- (1) 164 (2) 123 (3) 82 (4) 75

Sol. (2)

$$n(\text{total } 5) = \{1, 4), (2, 3), (3, 2), (4, 1)\} = 4$$
$$P(\text{success}) = \frac{4}{36} = \frac{1}{9}$$
$$P(\text{at least 4 success}) = P(4 \text{ success}) + P(5 \text{ success})$$
$$= {}^5C_4 \cdot \left(\frac{1}{9}\right)^4 \cdot \frac{8}{9} + {}^5C_5 \left(\frac{1}{9}\right)^5 = \frac{41}{9^5} = \frac{41}{3^{10}} = \frac{123}{3^{11}} = \frac{k}{3^{11}}$$
$$K = 123$$

6. Let $A = [a_{ij}]_{2 \times 2}$, where $a_{ij} \neq 0$ for all i, j and $A^2 = I$. Let a be the sum of all diagonal elements of A and $b = |A|$. Then $3a^2 + 4b^2$ is equal to :

- (1) 14 (2) 4 (3) 3 (4) 7

Sol. (2)

$$A^2 = I \Rightarrow |A|^2 = 1 \Rightarrow |A| = \pm 1 = b$$
$$\text{Let } A = \begin{bmatrix} \alpha & \beta \\ \gamma & \delta \end{bmatrix}$$
$$A^2 = \begin{bmatrix} \alpha & \beta \\ \gamma & \delta \end{bmatrix} \begin{bmatrix} \alpha & \beta \\ \gamma & \delta \end{bmatrix} = I$$
$$\begin{bmatrix} \alpha^2 + \beta\gamma & \alpha\beta + \beta\delta \\ \alpha\gamma + \gamma\delta & \gamma\beta + \delta^2 \end{bmatrix} = \begin{bmatrix} 1 & 0 \\ 0 & 1 \end{bmatrix} \Rightarrow \alpha^2 + \beta\gamma = 1$$
$$(\alpha + \delta)\beta = 0 \Rightarrow \alpha + \delta = 0 = a$$
$$(\alpha + \delta)\gamma = 0$$
$$\beta\gamma + \delta^2 = 0$$
$$\text{Now } 3a^2 + 4b^2 = 3(0)^2 + 4(1) = 4$$

7. Let $a_1, a_2, a_3, \dots, a_n$ be n positive consecutive terms of an arithmetic progression. If $d > 0$ is its common difference, then : $\lim_{n \rightarrow \infty} \sqrt{\frac{d}{n}} \left(\frac{1}{\sqrt{a_1} + \sqrt{a_2}} + \frac{1}{\sqrt{a_2} + \sqrt{a_3}} + \dots + \frac{1}{\sqrt{a_{n-1}} + \sqrt{a_n}} \right)$ is

- (1) $\frac{1}{\sqrt{d}}$ (2) 1 (3) \sqrt{d} (4) 0

Sol. (2)

$$\begin{aligned} & \lim_{n \rightarrow \infty} \sqrt{\frac{d}{n}} \left(\frac{\sqrt{a_1} - \sqrt{a_2}}{a_1 - a_2} + \frac{\sqrt{a_2} - \sqrt{a_3}}{a_2 - a_3} + \dots + \frac{\sqrt{a_{n-1}} - \sqrt{a_n}}{a_{n-1} - a_n} \right) \\ &= \lim_{n \rightarrow \infty} \sqrt{\frac{d}{n}} \left(\frac{\sqrt{a_1} - \sqrt{a_2} + \sqrt{a_2} - \sqrt{a_3} + \dots + \sqrt{a_{n-1}} - \sqrt{a_n}}{-d} \right) \\ &= \lim_{n \rightarrow \infty} \sqrt{\frac{d}{n}} \left(\frac{\sqrt{a_n} - \sqrt{a_1}}{d} \right) \\ &= \lim_{n \rightarrow \infty} \frac{1}{\sqrt{n}} \left(\frac{\sqrt{a_1 + (n-1)d} - \sqrt{a_1}}{\sqrt{d}} \right) \\ &= \lim_{n \rightarrow \infty} \frac{1}{\sqrt{d}} \left(\sqrt{\frac{a_1}{n} + d - \frac{d}{n}} - \frac{\sqrt{a_1}}{n} \right) \\ &= 1 \end{aligned}$$

8. If ${}^{2n}C_3 : {}^nC_3 : 10 : 1$, then the ratio $(n^2 + 3n) : (n^2 - 3n + 4)$ is :

- (1) 27 : 11 (2) 35 : 16 (3) 2 : 1 (4) 65 : 37

Sol. (3)

$$\begin{aligned} \frac{{}^{2n}C_3}{{}^nC_3} &= 10 \Rightarrow \frac{2n!(n-3)!}{(2n-3)!n!} = 10 \\ \frac{2n(2n-1)(2n-2)}{n(n-1)(n-2)} &= 10 \\ \frac{4(2n-1)}{n-2} &= 10 \Rightarrow 8n - 4 = 10n - 20 \\ 2n &= 16 \\ \text{Now } \frac{n^2 + 3n}{n^2 - 3n + 4} &= \frac{64 + 24}{64 - 24 + 4} = \frac{88}{44} = 2 \\ \text{Ans. 3} \end{aligned}$$

9. Let $A = \{x \in \mathbb{R} : [x + 3] + [x + 4] \leq 3\}$,

$$B = \left\{ x \in \mathbb{R} : 3^x \left(\sum_{r=1}^{\infty} \frac{3}{10^r} \right)^{x-3} < 3^{-3x} \right\}, \text{ where } [t] \text{ denotes greatest integer function. Then,}$$

- (1) $A \subset B, A \neq B$ (2) $A \cap B = \phi$ (3) $A = B$ (4) $B \subset C, A \neq B$

Sol. (3)

$$A = \{x \in \mathbb{R} : [x + 3] + [x + 4] \leq 3\},$$

$$2[x] + 7 \leq 3$$

$$2[x] \leq -4$$

$$[x] \leq -2 \Rightarrow x < -1 \quad \dots(A)$$

$$B = \left\{ x \in \mathbb{R} : 3^x \left(\sum_{r=1}^{\infty} \frac{3}{10^r} \right)^{x-3} < 3^{-3x} \right\}$$

$$3^x \left(\sum_{r=1}^{\infty} \frac{3}{10^r} \right)^{x-3} < 3^{-3x}$$

$$3^{2x-3} \left(\frac{\frac{1}{10}}{1 - \frac{1}{10}} \right)^{x-3} < 3^{-3x}$$

$$\Rightarrow \left(\frac{1}{9} \right)^{x-3} < 3^{-5x+3}$$

$$\Rightarrow 3^{6-2x} < 3^{3-5x}$$

$$\Rightarrow 6 - 2x < 3 - 5x$$

$$\Rightarrow 3 < -3x$$

$$\Rightarrow \boxed{x < -1} \quad \dots(B)$$

$$A = B$$

10. One vertex of a rectangular parallelepiped is at the origin O and the lengths of its edges along x, y and z axes are 3, 4 and 5 units respectively. Let P be the vertex (3, 4, 5). Then the shortest distance between the diagonal OP and an edge parallel to z axis, not passing through O or P is :

(1) $\frac{12}{5\sqrt{5}}$

(2) $12\sqrt{5}$

(3) $\frac{12}{5}$

(4) $\frac{12}{\sqrt{5}}$

Sol. (3)

Equation of OP is $\frac{x}{3} = \frac{y}{4} = \frac{z}{5}$

$a_1 = (0, 0, 0) \quad a_2 = (3, 0, 5)$

$b_1 = (3, 4, 5) \quad b_2 = (0, 0, 1)$

Equation of edge parallel to z axis

$$\frac{x-3}{0} = \frac{y-0}{0} = \frac{z-5}{1}$$

$$S.D = \frac{(\vec{a}_2 \cdot \vec{a}_1) \cdot (\vec{b}_1 \times \vec{b}_2)}{|\vec{b}_1 \times \vec{b}_2|}$$

$$\frac{\begin{vmatrix} 3 & 0 & 5 \\ 3 & 4 & 5 \\ 0 & 0 & 1 \end{vmatrix}}{\begin{vmatrix} \hat{i} & \hat{j} & \hat{k} \\ 3 & 4 & 5 \\ 0 & 0 & 1 \end{vmatrix}} = \frac{3(4)}{|4\hat{i} - 3\hat{j}|} = \frac{12}{5}$$

Sol. (3)

$$|x^2 - 8x + 15| = 2x - 7$$

$$x^2 - 8x + 15 = 2x - 7 \quad \& \quad x^2 - 8x + 15 = 7 - 2x$$

$$x^2 - 10x + 22 = 0 \quad \& \quad x^2 - 6x + 8 = 0$$

$$x_1 = 5 + \sqrt{3} \quad x_2 = 5 - \sqrt{3} \text{ (reject)} \quad x_3 = 4 \quad x_4 = 2 \text{ (reject)}$$

$$\text{Sum of roots is } = 5 + \sqrt{3} + 4 = 9 + \sqrt{3}$$

Ans. 3

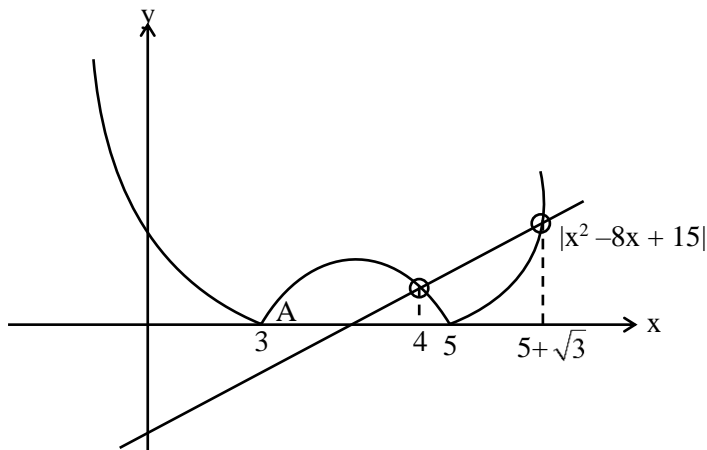

14. From the top A of a vertical wall AB of height 30 m, the angles of depression of the top P and bottom Q of a vertical tower PQ are 15° and 60° respectively, B and Q are on the same horizontal level. If C is a point on AB such that $CB = PQ$, then the area (in m^2) of the quadrilateral BCPQ is equal to :

- (1) $200(3 - \sqrt{3})$ (2) $300(\sqrt{3} + 1)$ (3) $300(\sqrt{3} - 1)$ (4) $600(\sqrt{3} - 1)$

Sol. (4)

$\triangle ABQ$

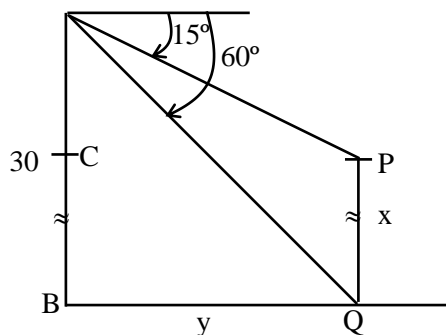

$$\frac{AB}{BQ} = \tan 60^\circ$$

$$BQ = \frac{30}{\sqrt{3}} = 10\sqrt{3} = y$$

& $\triangle ACP$

$$\frac{AC}{CP} = \tan 15^\circ \Rightarrow \frac{(30 - x)}{y} = (2 - \sqrt{3})$$

$$30 - x = 10\sqrt{3} (2 - \sqrt{3})$$

$$30 - x = 20\sqrt{3} - 30$$

$$x = 60 - 20\sqrt{3}$$

$$\text{Area} = x \cdot y = 20(3 - \sqrt{3}) \cdot 10\sqrt{3}$$

$$= 600(\sqrt{3} - 1)$$

Ans. (4)

15. Let $\vec{a} = 2\hat{i} + 3\hat{j} + 4\hat{k}$, $\vec{b} = \hat{i} - 2\hat{j} - 2\hat{k}$ and $\vec{c} = -\hat{i} + 4\hat{j} + 3\hat{k}$. If \vec{d} is a vector perpendicular to both \vec{b} and \vec{c} , and $\vec{a} \cdot \vec{d} = 18$, then $[\vec{a} \times \vec{d}]^2$ is equal to :

(1) 760

(2) 640

(3) 720

(4) 680

Sol. (3)

$$\vec{d} = \lambda (\vec{b} \times \vec{c})$$

$$\text{For } \lambda : \vec{a} \cdot \vec{d} = 18 \Rightarrow \lambda [\vec{a} \cdot (\vec{b} \times \vec{c})] = 18$$

$$\Rightarrow \lambda \begin{vmatrix} 2 & 3 & 4 \\ 1 & -2 & -2 \\ -1 & 4 & 3 \end{vmatrix} = 18$$

$$\Rightarrow \lambda (4 - 3 + 8) = 18 \Rightarrow \lambda = 2$$

$$\Rightarrow \vec{d} = 2(2\hat{i} - \hat{j} + 2\hat{k})$$

$$\text{Hence } |\vec{a} \times \vec{d}|^2 = a^2 d^2 - (\vec{a} \cdot \vec{d})^2$$

$$= 29 \cdot 36 - (18)^2 = 18(58 - 18)$$

$$= 18 \cdot 40 = 720$$

Ans. 3

16. If $2x^y + 3y^x = 20$, then $\frac{dy}{dx}$ at (2, 2) is equal to :

(1) $-\left(\frac{3 + \log_e 8}{2 + \log_e 4}\right)$

(2) $-\left(\frac{2 + \log_e 8}{3 + \log_e 4}\right)$

(3) $-\left(\frac{3 + \log_e 4}{2 + \log_e 8}\right)$

(4) $-\left(\frac{3 + \log_e 16}{4 + \log_e 8}\right)$

Sol. (2)

$$2x^y + 3y^x = 20$$

$$v_1^{v_2} \left(v_2 \frac{1}{v_1} + \ln v_1 \cdot v_2^1 \right)$$

$$2x^y \left(y \cdot \frac{1}{x} + \ln x \cdot \frac{dy}{dx} \right) + 3y^x \left(x \cdot \frac{1}{y} \cdot \frac{dy}{dx} + \ln y \cdot 1 \right) = 0$$

Put (2, 2)

$$2 \cdot 4 \left(1 + \ln 2 \cdot \frac{dy}{dx} \right) + 3 \cdot 4 \left(1 \cdot \frac{dy}{dx} + \ln 2 \right) = 0$$

$$\frac{dy}{dx} [8 \ln 2 + 12] + 8 + 12 \ln 2 = 0$$

$$\frac{dy}{dx} = - \left[\frac{2 + 3 \ln 2}{3 + 2 \ln 2} \right] = - \left[\frac{2 + \ln 8}{3 + \ln 4} \right]$$

17. If the system of equations

$$x + y + az = b$$

$$2x + 5y + 2z = 6$$

$$x + 2y + 3z = 3$$

has infinitely many solutions, then $2a + 3b$ is equal to :

(1) 28

(2) 20

(3) 25

(4) 23

Sol. (4)

$$x + y + az = b$$

$$2x + 5y + 2z = 6$$

$$x + 2y + 3z = 3$$

For ∞ solution

$$\Delta = 0, \Delta_x = 0, \Delta_y = 0, \Delta_z = 0$$

$$\Delta = \begin{vmatrix} 1 & 1 & a \\ 2 & 5 & 2 \\ 1 & 2 & 3 \end{vmatrix} = 0 \Rightarrow 11 - 4 - a = 0 \Rightarrow a = 7$$

$$\Delta_z = \begin{vmatrix} 1 & 1 & b \\ 2 & 5 & 6 \\ 1 & 2 & 3 \end{vmatrix} = 0 \Rightarrow 3 - 0 - b = 0 \Rightarrow b = 3$$

$$\text{Hence } 2a + 3b = 23$$

Ans. 4

18. Statement $(P \Rightarrow Q) \wedge (R \Rightarrow Q)$ is logically equivalent to:

(1) $(P \vee R) \Rightarrow Q$ (2) $(P \Rightarrow R) \vee (Q \Rightarrow R)$ (3) $(P \Rightarrow R) \wedge (Q \Rightarrow R)$ (4) $(P \wedge R) \Rightarrow Q$

Sol. (1)

$$(P \Rightarrow Q) \wedge (R \Rightarrow Q)$$

$$\text{We know that } P \Rightarrow Q \equiv \sim P \vee Q$$

$$\Rightarrow (\sim P \vee Q) \wedge (\sim R \vee Q)$$

$$\Rightarrow (\sim P \wedge \sim R) \vee Q$$

$$\Rightarrow \sim (P \vee R) \vee Q$$

$$\Rightarrow (P \vee R) \Rightarrow Q$$

19. Let $5f(x) + 4f\left(\frac{1}{x}\right) = \frac{1}{x} + 3, x > 0$. Then $18 \int_1^2 f(x) dx$ is equal to :

(1) $10 \log_e 2 - 6$

(2) $10 \log_e 2 + 6$

(3) $5 \log_e 2 - 3$

(4) $5 \log_e 2 + 3$

Sol. (1)

$$5f(x) + 4f\left(\frac{1}{x}\right) = \frac{1}{x} + 3 \quad \dots(1)$$

$$x \rightarrow \frac{1}{x}$$

$$5f\left(\frac{1}{x}\right) + 4f(x) = x + 3 \quad \dots(2)$$

$$(1) \times 5 - (2) \times 4$$

$$\Rightarrow f(x) = \frac{5}{9x} - \frac{4}{9}x + \frac{1}{3}$$

$$\Rightarrow 18 \int_1^2 f(x) dx = 18 \left(\frac{5}{9} \ln 2 - \frac{4}{9} \times \frac{3}{2} + \frac{1}{3} \right)$$

$$= 10 \ln 2 - 6$$

20. The mean and variance of a set of 15 numbers are 12 and 14 respectively. The mean and variance of another set of 15 numbers are 14 and σ^2 respectively. If the variance of all the 30 numbers in the two sets is 13, then σ^2 is equal to :

- (1) 12 (2) 10 (3) 11 (4) 9

Sol. (2)

$$\text{Combine var.} = \frac{n_1\sigma^2 + n_2\sigma^2}{n_1 + n_2} + \frac{n_1n_2(m_1 - m_2)^2}{(n_1 + n_2)^2}$$

$$13 = \frac{15 \cdot 14 + 15 \cdot \sigma^2}{30} + \frac{15 \cdot 15(12 - 14)^2}{30 \times 30}$$

$$13 = \frac{14 + \sigma^2}{2} + \frac{4}{4}$$

$$\sigma^2 = 10$$

SECTION-B

21. Let the tangents to the curve $x^2 + 2x - 4y + 9 = 0$ at the point P(1, 3) on it meet the y-axis at A. Let the line passing through P and parallel to the line $x - 3y = 6$ meet the parabola $y^2 = 4x$ at B. If B lies on the line $2x - 3y = 8$, then $(AB)^2$ is equal to _____.

Sol. (292)

$$C : x^2 + 2x - 4y + 9 = 0$$

$$C : (x + 1)^2 = 4(y - 2)$$

$$T_{P(1,3)} : x \cdot 1 + (x + 1) - 2(y + 3) + 9 = 0$$

$$: 2x - 2y + 4 = 0$$

$$T_p : x - y + 2 = 0$$

$$A : (0, 2)$$

$$\text{Line } \parallel \text{ to } x - 3y = 6 \text{ passes } (1, 3) \text{ is } x - 3y + 8 = 0$$

$$\text{Meet parabola : } y^2 = 4x$$

$$\Rightarrow y^2 = 4(3y - 8)$$

$$\Rightarrow y^2 - 12y + 32 = 0$$

$$\Rightarrow (y - 8)(y - 4) = 0$$

$$\Rightarrow \text{point of intersection are}$$

$$(4, 4) \text{ \& } (16, 8) \text{ lies on } 2x - 3y = 8$$

$$\text{Hence A : } (0, 2)$$

$$B : (16, 8)$$

$$(AB)^2 = 256 + 36 = 292$$

22. Let the point $(p, p + 1)$ lie inside the region $E = \{(x, y) : 3 - x \leq y \leq \sqrt{9 - x^2}, 0 \leq x \leq 3\}$. If the set of all values of p is the interval (a, b) , then $b^2 + b - a^2$ is equal to _____.

Sol. (3)

$$3 - x \leq y \leq \sqrt{9 - x^2}; 0 \leq x \leq 3$$

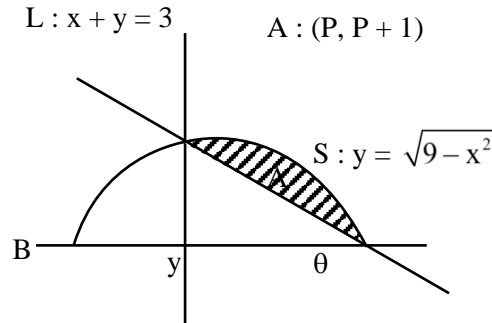

$$L(A) > 0 \Rightarrow P + P + 1 - 3 > 0 \Rightarrow P > 1 \quad \dots(1)$$

$$S(A) < 0 \Rightarrow P + 1 - \sqrt{9 - P^2} < 0$$

$$\Rightarrow P + 1 < \sqrt{9 - P^2}$$

$$\Rightarrow P + 2P + 1 < 9 - P^2$$

$$\Rightarrow 2P^2 + 2P - 8 < 0$$

$$\Rightarrow P^2 + P - 4 < 0$$

$$\Rightarrow P \in \left(\frac{-1 - \sqrt{17}}{2}, \frac{-1 + \sqrt{17}}{2} \right) \quad \dots(2)$$

$$(1) \cap (2) P \in \left(1, \frac{\sqrt{17} - 1}{2} \right) \equiv (a, b)$$

$$b^2 + b - a^2 = 4 - 1 = 3$$

23. Let $y = y(x)$ be a solution of the differential $(x \cos x)dy + (x y \sin x + y \cos x - 1)dx = 0$, $0 < x < \frac{\pi}{2}$. If

$$\frac{\pi}{3} y \left(\frac{\pi}{3} \right) = \sqrt{3}, \text{ then } \left| \frac{\pi}{6} y'' \left(\frac{\pi}{6} \right) + 2y' \left(\frac{\pi}{6} \right) \right| \text{ is equal to } \underline{\hspace{2cm}}.$$

Sol. (2)

$$(x \cos x) dy + (x y \sin x + y \cos x - 1) dx = 0, 0 < x < \frac{\pi}{2}$$

$$\frac{dy}{dx} + \left(\frac{x \sin x + \cos x}{x \cos x} \right) y = \frac{1}{x \cos x}$$

$$\text{IF} = x \sec x$$

$$y \cdot x \sec x = \int \frac{x \sec x}{x \cos x} dx = \tan x + c$$

$$\text{Since } y \left(\frac{\pi}{3} \right) = \frac{3\sqrt{3}}{\pi} \quad \text{Hence } c = \sqrt{3}$$

$$\text{Hence } \left| \frac{\pi}{6} y'' \left(\frac{\pi}{6} \right) + y' \left(\frac{\pi}{6} \right) \right| = |-2| = 2$$

24. Let $a \in \mathbb{Z}$ and $[t]$ be the greatest integer $\leq t$. Then the number of points, where the function $f(x) = [a + 13 \sin x]$, $x \in (0, \pi)$ is not differentiable, is _____.

Sol. (25)

$$f(x) = [a + 13 \sin x] = a + [13 \sin x] \text{ in } (0, \pi)$$

$$x \in (0, \pi)$$

$$\Rightarrow 0 < 13 \sin x \leq 13$$

$$\Rightarrow [13 \sin x] = \{0, 1, 2, 3, \dots, 12, 13\}$$

$$\begin{array}{ccc} \downarrow & & \downarrow \downarrow \\ 2 & & 2 \quad 1 \end{array}$$

Total point of N.D. = 25.

25. If the area of the region $S = \{(x, y) : 2y - y^2 \leq x^2 \leq 2y, x \geq y\}$ is equal to $\frac{n+2}{n+1} - \frac{\pi}{n-1}$, then the natural number n is equal to _____.

Sol. (5)

$$x^2 + y^2 - 2y \geq 0 \text{ \& } x^2 - 2y \leq 0, x \geq y$$

$$\text{Hence required area} = \frac{1}{2} \times 2 \times 2 - \int_0^2 \frac{x^2}{2} dx - \left(\frac{\pi}{4} - \frac{1}{2} \right)$$

$$= \frac{7}{6} - \frac{\pi}{4} \Rightarrow n = 5$$

26. The number of ways of giving 20 distinct oranges to 3 children such that each child gets at least one orange is _____.

Sol. 3483638676

Total – (one child receive no orange + two child receive no orange)

$$= 3^{20} - ({}^3C_1 (2^{20} - 2) + {}^3C_2 1^{20}) = 3483638676$$

27. Let the image of the point $P(1, 2, 3)$ in the plane $2x - y + z = 9$ be Q . If the coordinates of the point R are $(6, 10, 7)$. then the square of the area of the triangle PQR is _____.

Sol. (594)

Let $Q(\alpha, \beta, \gamma)$ be the image of P , about the plane

$$2x - y + z = 9$$

$$\frac{\alpha - 1}{2} = \frac{\beta - 2}{-1} = \frac{\gamma - 3}{1} = 2$$

$$\Rightarrow \alpha = 5, \beta = 0, \gamma = 5$$

$$\text{Then area of triangle } PQR \text{ is} = \frac{1}{2} |\overrightarrow{PQ} \times \overrightarrow{PR}|$$

$$= \left| -12\hat{i} - 3\hat{j} + 21\hat{k} \right| = \sqrt{144 + 9 + 441} = \sqrt{594}$$

Square of area = 594

28. A circle passing through the point $P(\alpha, \beta)$ in the first quadrant touches the two coordinate axes at the points A and B . The point P is above the line AB . The point Q on the line segment AB is the foot of perpendicular from P on AB . If PQ is equal to 11 units, then value of $\alpha\beta$ is _____.

Sol. (121)

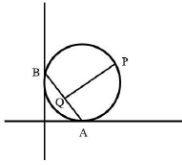

Let equation of circle is $(x - a)^2 + (y - a)^2 = a^2$

which is passing through P (α, β)

then $(\alpha - a)^2 + (\beta - a)^2 = a^2$

$\alpha^2 + \beta^2 - 2\alpha a - 2\beta a + a^2 = 0$

Here equation of AB is $x + y = a$

Let Q (α', β') be foot of perpendicular of P on AB

$$\frac{\alpha' - \alpha}{1} = \frac{\beta' - \beta}{1} = \frac{-(\alpha + \beta - a)}{2}$$

$$PQ^2 = (\alpha' - \alpha)^2 + (\beta' - \beta)^2 = \frac{1}{4} (\alpha + \beta - a)^2 + \frac{1}{4} (\alpha + \beta - a)^2$$

$$121 = \frac{1}{2} (\alpha + \beta - a)^2$$

$$242 = \alpha^2 + \beta^2 - 2\alpha a - 2\beta a + a^2 + 2\alpha\beta$$

$$242 = 2\alpha\beta$$

$$\Rightarrow \alpha\beta = 121$$

29. The coefficient of x^{18} in the expansion of $\left(x^4 - \frac{1}{x^3}\right)^{15}$ is _____.

Sol. (5005)

$$\left(x^4 - \frac{1}{x^3}\right)^{15}$$

$$T_{r+1} = {}^{15}C_r (x^4)^{15-r} \left(\frac{-1}{x^3}\right)^r$$

$$60 - 7r = 18$$

$$r = 6$$

$$\text{Hence coeff. of } x^{18} = {}^{15}C_6 = 5005$$

30. Let $A = \{1, 2, 3, 4, \dots, 10\}$ and $B = \{0, 1, 2, 3, 4\}$. The number of elements in the relation $R = \{(a, b) \in A \times A : 2(a - b)^2 + 3(a - b) \in B\}$ is _____.

Sol. (18)

$$A = \{1, 2, 3, \dots, 10\}$$

$$B = \{0, 1, 2, 3, 4\}$$

$$R = \{(a, b) \in A \times A : 2(a - b)^2 + 3(a - b) \in B\}$$

$$\text{Now } 2(a - b)^2 + 3(a - b) = (a - b)(2(a - b) + 3)$$

$$\Rightarrow a = b \text{ or } a - b = -2$$

When $a = b \Rightarrow 10$ order pairs

When $a - b = -2 \Rightarrow 8$ order pairs

$$\text{Total} = 18$$

Sol. (3)

At terminal velocity, net force on the ball is Zero.

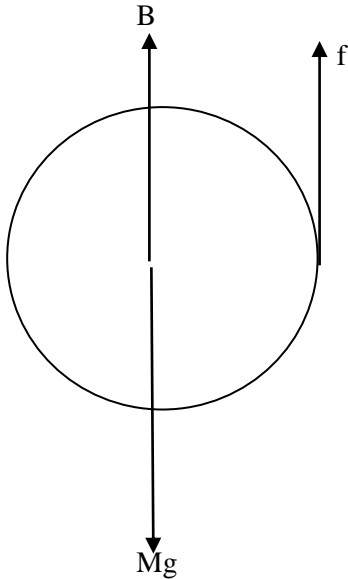

$$Mg = f + B$$

$$\Rightarrow Mg = f + V_{ball}\rho_o g \dots (i)$$

$$\text{Volume of ball} = \frac{M}{\rho}$$

From eq (i),

$$Mg = f + \frac{M}{\rho}\rho_o g$$

$$\Rightarrow f = Mg - \frac{M}{\rho}\rho_o g$$

$$\Rightarrow f = Mg\left(1 - \frac{\rho_o}{\rho}\right)$$

35. A small block of mass 100 g is tied to a spring of spring constant 7.5 N/m and length 20 cm. The other end of spring is fixed at a particular point A. If the block moves in a circular path on a smooth horizontal surface with constant angular velocity 5 rad/s about point A, then tension in the spring is –

- (1) 0.75 N (2) 1.5 N (3) 0.25 N (4) 0.50 N

Sol. (1)

$$kx = m\omega^2 r$$

$$\Rightarrow kx = 0.1 \times 25 \times (0.2 + x)$$

$$\Rightarrow 7.5x = 2.5(0.2 + x)$$

$$\Rightarrow 3x = 0.2 + x$$

$$\Rightarrow 2x = 0.2$$

$$\Rightarrow x = 0.1\text{m}$$

Now, tension in the spring = $kx = 7.5 \times 0.1 \text{ N} = 0.75 \text{ N}$

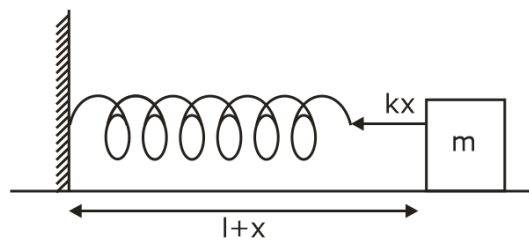

36. A particle is moving with constant speed in a circular path. When the particle turns by an angle 90° , the ratio of instantaneous velocity to its average velocity is $\pi : x\sqrt{2}$. The value of x will be -

- (1) 7 (2) 2 (3) 1 (4) 5

Sol. (2)

$$V_A = v\hat{j}$$

$$\text{And } V_B = -v\hat{i}$$

$$\text{Time to reach from A to B} = \frac{2\pi R}{4} \times \frac{1}{v} = \frac{\pi R}{2v}$$

$$\text{Displacement from A to B} = R\sqrt{2}$$

$$\text{Now, Average velocity from A to B} = \frac{\text{Displacement}}{\text{Time}} = \frac{R\sqrt{2}}{\frac{\pi R}{2v}} = \frac{2\sqrt{2}v}{\pi}$$

Instantaneous velocity at B is $-v\hat{i}$

$$\text{According to question, } \frac{\text{instantaneous velocity}}{\text{average velocity}} = \frac{\pi}{x\sqrt{2}}$$

$$\frac{v}{\frac{2\sqrt{2}v}{\pi}} = \frac{\pi}{x\sqrt{2}}$$

$$\Rightarrow \frac{\pi}{2\sqrt{2}} = \frac{\pi}{x\sqrt{2}}$$

$$\Rightarrow x = 2$$

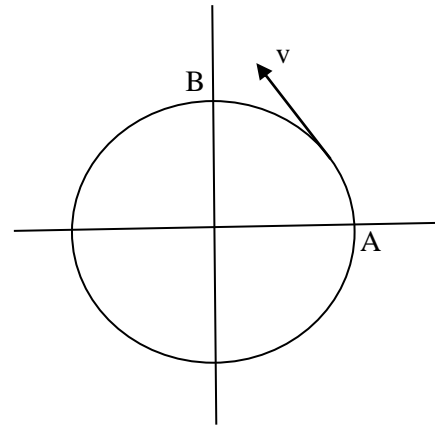

37. Two resistances are given as $R_1 = (10 \pm 0.5) \Omega$ and $R_2 = (15 \pm 0.5)\Omega$. The percentage error in the measurement of equivalent resistance when they are connected in parallel is -

(1) 2.33

(2) 4.33

(3) 5.33

(4) 6.33

Sol. (2)

$$\text{In parallel combination, } \frac{1}{R_{eq}} = \frac{1}{R_1} + \frac{1}{R_2}$$

$$\Rightarrow \frac{1}{R_{eq}} = \frac{1}{10} + \frac{1}{15} = \frac{5}{30} = \frac{1}{6}$$

Now, for error calculation,

$$\frac{dR_{eq}}{R_{eq}^2} = \frac{dR_1}{R_1^2} + \frac{dR_2}{R_2^2}$$

$$\Rightarrow \frac{dR_{eq}}{36} = \frac{0.5}{100} + \frac{0.5}{225}$$

$$dR_{eq} = 36 \times 0.5 \times \left(\frac{13}{900}\right) = 18 \times \frac{13}{900} = \frac{26}{100} = 0.26$$

$$\text{Now, } \frac{dR_{eq}}{R_{eq}} \times 100 = \frac{0.26}{6} \times 100 = \frac{26}{6} = 4.33$$

38. For a uniformly charged thin spherical shell, the electric potential (V) radially away from the centre (O) of shell can be graphically represented as -

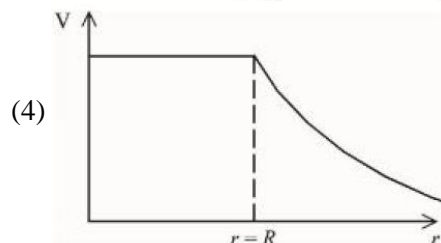
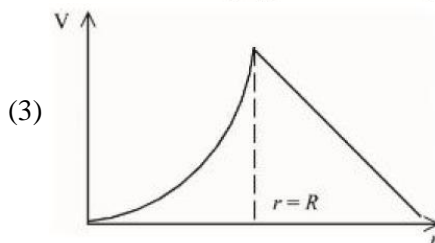
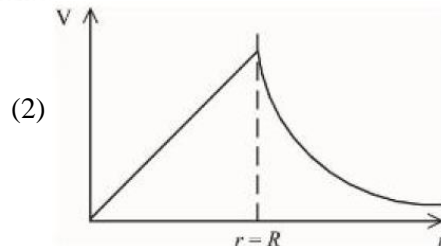
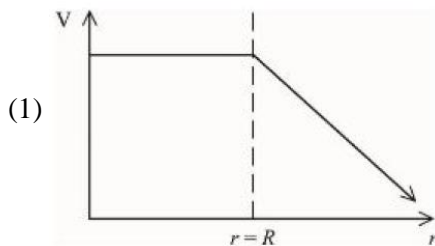
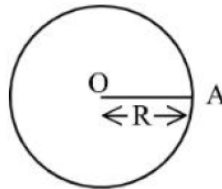

Sol. (4)

For $r \leq R, V = \frac{KQ}{R}$, i.e., Constant everywhere inside.

For $r > R, V = \frac{KQ}{r}$, i.e., Decreases with r .

39. A long straight wire of circular cross-section (radius a) is carrying steady current I . The current I is uniformly distributed across this cross-section. The magnetic field is

(1) zero in the region $r < a$ and inversely proportional to r in the region $r > a$

(2) inversely proportional to r in the region $r < a$ and uniform throughout in the region $r > a$

(3) directly proportional to r in the region $r < a$ and inversely proportional to r in the region $r > a$

(4) uniform in the region $r < a$ and inversely proportional to distance r from the axis, in the region $r > a$

Sol. (3)

It is a case of solid infinite current carrying wire.

Using ampere circuital law,

CASE I: if $r \leq R$

$$B = \frac{\mu_0 i}{2\pi R^2} r$$

CASE II: $r > R$

$$B = \frac{\mu_0 i}{2\pi r}$$

40. By what percentage will the transmission range of a TV tower be affected when the height of the tower is increased by 21% ?

(1) 12%

(2) 15%

(3) 14%

(4) 10%

Sol. (4)

New range is given by $\sqrt{2R(h + 0.21h)}$

$$= \sqrt{2Rh \times 1.21}$$

$$= 1.1\sqrt{2Rh}$$

It means new range increases by 10 %.

41. The number of air molecules per cm^3 increased from 3×10^{19} to 12×10^{19} . The ratio of collision frequency of air molecules before and after the increase in the number respectively is :

(1) 0.25

(2) 0.75

(3) 1.25

(4) 0.50

Sol. (1)

Collision frequency is given by $Z = n\pi d^2 V_{avg}$, where n is number of molecules per unit volume.

$$\frac{Z_1}{Z_2} = \frac{n_1}{n_2} = \frac{3}{12} = \frac{1}{4} = 0.25$$

42. The energy levels of an hydrogen atom are shown below. The transition corresponding to emission of shortest wavelength is

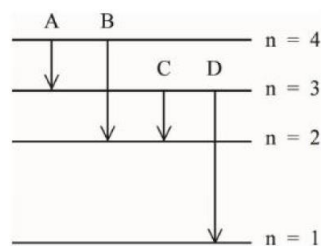

(1) A

(2) D

(3) C

(4) B

Sol. (2)

$$E = \frac{hc}{\lambda}$$

$$\Rightarrow \lambda = \frac{hc}{E}$$

For λ_{min} , E must be maximum.

And E is maximum for D.

43. For the plane electromagnetic wave given by $E = E_0 \sin(\omega t - kx)$ and $B = B_0 \sin(\omega t - kx)$, the ratio of average electric energy density to average magnetic energy density is
 (1) 2 (2) 1/2 (3) 1 (4) 4

Sol. (3)
 In EM waves, average electric energy density is equal to average magnetic energy density.

$$\frac{1}{4} \epsilon_0 E_0^2 = \frac{1}{4\mu_0} B_0^2$$

44. A planet has double the mass of the earth. Its average density is equal to that of the earth. An object weighing W on earth will weigh on that planet:
 (1) $2^{1/3} W$ (2) $2 W$ (3) W (4) $2^{2/3} W$

Sol. (1)
 Average Density of planet = average density of earth

$$\frac{M_e}{\frac{4}{3}\pi R_e^3} = \frac{M_p}{\frac{4}{3}\pi R_p^3}$$

$$\Rightarrow \frac{M_e}{R_e^3} = \frac{2M_e}{R_p^3}$$

$$\Rightarrow R_p = 2^{1/3} R_e \text{ ----- (i)}$$

Now, $g = \frac{GM}{R^2}$

$$\frac{g_e}{g_p} = \frac{M_e}{R_e^2} \times \frac{R_p^2}{2M_e} = 2^{2/3 - 1} = 2^{-1/3}$$

$$\Rightarrow g_p = 2^{1/3} g_e$$

$$\Rightarrow W_p = 2^{1/3} W_e$$

45. The resistivity (ρ) of semiconductor varies with temperature. Which of the following curve represents the correct behavior

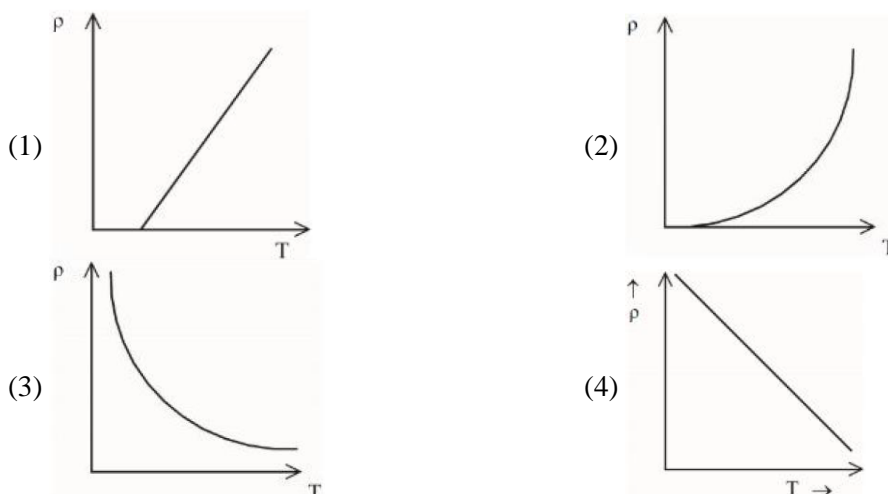

Sol. (3)
 A semiconductor starts conduction more as the temperature increases. It means resistance decreases with increase in temperature. So, if temperature increases, its resistivity decreases.

Also, $\rho = \frac{m}{ne^2\tau}$

As Temperature increase, τ decreases but n increases and n is dominant over τ .

46. A monochromatic light wave with wavelength λ_1 and frequency ν_1 in air enters another medium. If the angle of incidence and angle of refraction at the interface are 45° and 30° respectively, then the wavelength λ_2 and frequency ν_2 of the refracted wave are :

- (1) $\lambda_2 = \frac{1}{\sqrt{2}}\lambda_1, \nu_2 = \nu_1$ (2) $\lambda_2 = \lambda_1, \nu_2 = \frac{1}{\sqrt{2}}\nu_1$
 (3) $\lambda_2 = \lambda_1, \nu_2 = \sqrt{2}\nu_1$ (4) $\lambda_2 = \sqrt{2}\lambda_1, \nu_2 = \nu_1$

Sol. (1)
 $1 \times \sin 45 = \mu \sin 30$
 $\Rightarrow \frac{1}{\sqrt{2}} = \mu \times \frac{1}{2}$
 $\Rightarrow \mu = \sqrt{2}$ ----- (i)
 Now, $\frac{\mu_1}{\mu_2} = \frac{v_2}{v_1} = \frac{\lambda_2}{\lambda_1}$ ----- (ii)
 Using eq (i) and (ii),
 $\lambda_2 = \frac{1}{\sqrt{2}} \lambda_1$
 And $v_2 = \frac{1}{\sqrt{2}} v_1$
 Now, for relation between frequencies,
 Frequency, $v = \frac{v}{\lambda}$
 Or $\frac{v_1}{v_2} = \frac{v_1}{v_2} \times \frac{\lambda_2}{\lambda_1} = 1$
 $v_1 = v_2$

47. A mass m is attached to two strings as shown in figure. The spring constants of two springs are K_1 and K_2 . For the frictionless surface, the time period of oscillation of mass m is

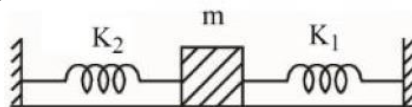

- (1) $2\pi \sqrt{\frac{m}{K_1 - K_2}}$ (2) $\frac{1}{2\pi} \sqrt{\frac{K_1 - K_2}{m}}$ (3) $\frac{1}{2\pi} \sqrt{\frac{K_1 + K_2}{m}}$ (4) $2\pi \sqrt{\frac{m}{K_1 + K_2}}$

Sol. (4)
 Both the springs are in parallel.
 $K_{eq} = K_1 + K_2$
 $T = 2\pi \sqrt{\frac{m}{K_{eq}}} = 2\pi \sqrt{\frac{m}{K_1 + K_2}}$

48. Name the logic gate equivalent to the diagram attached

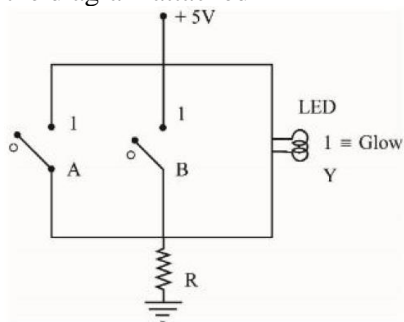

- (1) NOR (2) OR (3) NAND (4) AND

Sol. (1)

A	B	Y
0	0	1
1	0	0
0	1	0
1	1	0

NOR gate

49. The induced emf can be produced in a coil by
 A. moving the coil with uniform speed inside uniform magnetic field
 B. moving the coil with non uniform speed inside uniform magnetic field
 C. rotating the coil inside the uniform magnetic field
 D. changing the area of the coil inside the uniform magnetic field

- Choose the correct answer from the options given below :
 (1) B and D only (2) C and D only (3) B and C only (4) A and C only

Sol. (2)

Induced emf can be induced in a coil by changing magnetic flux.

$$\text{And } \phi = \vec{B} \cdot \vec{dA}$$

By rotating coil, angle between coil and magnetic field changes and hence flux changes.

By changing area, magnetic flux changes.

50. Given below are two statements : one is labelled as **Assertion A** and the other is labelled as **Reason R**.

Assertion A : When a body is projected at an angle 45° , it's range is maximum.

Reason R : For maximum range, the value of $\sin 2\theta$ should be equal to one.

In the light of the above statements, choose the correct answer from the options given below :

- (1) Both A and R are correct but R is NOT the correct explanation of A
- (2) A is false but R is true
- (3) Both A and R are correct and R is the correct explanation of A
- (4) A is true but R is false

Sol. (3)

For a ground to ground projectile, Horizontal range is given by $R = \frac{u^2 \sin 2\theta}{g}$

And for R_{max} , $\sin 2\theta$ must be maximum.

SECTION - B

51. Two identical circular wires of radius 20 cm and carrying current $\sqrt{2}$ A are placed in perpendicular planes as shown in figure. The net magnetic field at the centre of the circular wires is _____ $\times 10^{-8}$ T.

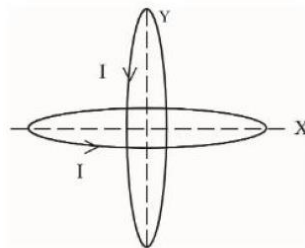

(Take $\pi = 3.14$)

Sol. (628)

$$\vec{B}_{net} = \frac{\mu_0 i}{2r} \hat{i} + \frac{\mu_0 i}{2r} \hat{j}$$

$$\Rightarrow B_{net} = \frac{\mu_0 i}{2r} \sqrt{2} = 4\pi \times 10^{-7} \times \sqrt{2} \times \sqrt{2} \times \frac{1}{2 \times 0.2} = 2 \times 3.14 \times 10^{-6} = 628 \times 10^{-8} \text{ T}$$

52. A steel rod has a radius of 20 mm and a length of 2.0 m. A force of 62.8 kN stretches it along its length. Young's modulus of steel is 2.0×10^{11} N/m². The longitudinal strain produced in the wire is _____ $\times 10^{-5}$

Sol. (25)

$$Y = \frac{\text{stress}}{\text{strain}}$$

$$\Rightarrow \text{strain} = \frac{\text{stress}}{Y} = \frac{F}{AY} = \frac{62.8 \times 1000}{\pi r^2 \times 2 \times 10^{11}} = \frac{62.8 \times 1000}{3.14 \times 400 \times 10^{-6} \times 2 \times 10^{11}} = \frac{200}{8} \times 10^{-5} = 25 \times 10^{-5}$$

53. The length of a metallic wire is increased by 20% and its area of cross section is reduced by 4%. The percentage change in resistance of the metallic wire is _____

Sol. (25)

$$R = \frac{\rho l}{A}$$

$$R' = \frac{\rho \times 1.2l}{0.96A} = \frac{10}{8} \times R = 1.25 R$$

It means 25 % increase in Resistance.

54. The radius of fifth orbit of the Li^{++} is _____ $\times 10^{-12}$ m.

Take : radius of hydrogen atom = 0.51 \AA

Sol. (425)

$$r_n = \frac{0.51n^2}{Z} A^0$$

For Li^{++} , $z=3$.

$$\text{So } r_5 = 0.51 \times \frac{25}{3} \times 10^{-10} \text{m} = 17 \times 25 \times 10^{-12} \text{m} = 425 \times 10^{-12} \text{m}$$

55. A particle of mass 10 g moves in a straight line with retardation $2x$, where x is the displacement in SI units. Its

loss of kinetic energy for above displacement is $\left(\frac{10}{x}\right)^{-n}$ J. The value of n will be _____

Sol. (2)

Given, $a = -2x$

$$\Rightarrow \frac{v dv}{dx} = -2x$$

$$\Rightarrow v dv = -2x dx$$

$$\Rightarrow \int_{v_1}^{v_2} v dv = -2 \int_0^x x dx$$

$$\Rightarrow \frac{v_2^2}{2} - \frac{v_1^2}{2} = -\frac{2x^2}{2}$$

$$\Rightarrow \frac{mv_1^2}{2} - \frac{mv_2^2}{2} = mx^2 = \frac{10}{1000} x^2 = 10^{-2} x^2 = \left(\frac{10}{x}\right)^{-2}$$

$n=2$.

56. An ideal transformer with purely resistive load operates at 12 kV on the primary side. It supplies electrical energy to a number of nearby houses at 120 V. The average rate of energy consumption in the houses served by the transformer is 60 kW. The value of resistive load (R_s) required in the secondary circuit will be _____ $\text{m}\Omega$.

Sol. (240)

$$\frac{V_s}{V_p} = \frac{N_s}{N_p}$$

$$\Rightarrow \frac{120}{12000} = \frac{N_s}{N_p}$$

$$\Rightarrow \frac{N_s}{N_p} = \frac{1}{100} \text{ --- (i)}$$

For an ideal transformer, input power = Output power

And power is given by $P = iV$

$$i_p V_p = i_s V_s = 60000 \text{W}$$

$$i_p = \frac{60000}{12000} = 5$$

$$\text{Now, } R_p = \frac{V_p}{i_p} = \frac{12000}{5} = 2400 \Omega$$

$$R_s = \frac{V_s}{i_s} = \frac{120}{60000/120} = 120 \times \frac{120}{60000} = \frac{120}{500} = 0.240 \Omega = 240 \text{ m}\Omega$$

57. A parallel plate capacitor with plate area A and plate separation d is filled with a dielectric material of dielectric constant $K = 4$. The thickness of the dielectric material is x , where $x < d$.

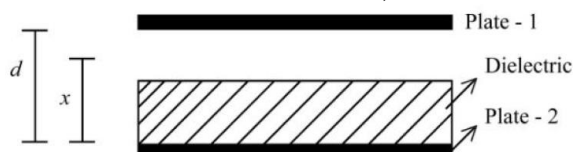

Let C_1 and C_2 be the capacitance of the system for $x = \frac{1}{3}d$ and $x = \frac{2d}{3}$, respectively. If $C_1 = 2\mu\text{F}$ the value of C_2 is _____ μF

Sol. (3)

$$C_1 = \frac{\frac{\epsilon_0 A}{\frac{2d}{3}} \times \frac{4\epsilon_0 A}{\frac{d}{3}}}{\frac{\epsilon_0 A}{\frac{2d}{3}} + \frac{4\epsilon_0 A}{\frac{d}{3}}} = \frac{18}{2+12} \frac{\epsilon_0 A}{d} = 18 \times \frac{2}{27} \frac{\epsilon_0 A}{d} = \frac{4}{3} \frac{\epsilon_0 A}{d}$$

According to qn, $\frac{4}{3} \frac{\epsilon_0 A}{d} = 2 \Rightarrow \frac{\epsilon_0 A}{d} = \frac{3}{2}$ ----- (i)

$$\text{Now, } C_2 = \frac{\frac{\epsilon_0 A}{\frac{d}{3}} \times \frac{4\epsilon_0 A}{\frac{2d}{3}}}{\frac{\epsilon_0 A}{\frac{d}{3}} + \frac{4\epsilon_0 A}{\frac{2d}{3}}} = \frac{18}{3+6} \frac{\epsilon_0 A}{d} = 2 \times \frac{\epsilon_0 A}{d} = 2 \times \frac{3}{2} = 3$$

58. Two identical solid spheres each of mass 2 kg and radii 10 cm are fixed at the ends of a light rod. The separation between the centres of the spheres is 40 cm. The moment of inertia of the system about an axis perpendicular to the rod passing through its middle point is _____ $\times 10^{-3}$ kg-m²

Sol. (176)

Using parallel axis theorem,

$$I_{sys} = \left(\frac{2}{5} mr^2 + md^2 \right) \times 2$$

$$\Rightarrow I_{sys} = \left(\frac{2}{5} \times 2 \times 0.01 + 2 \times 0.04 \right) \times 2 = (0.008 + 0.08) \times 2 = 0.088 \times 2 = 176 \times 10^{-3}$$

59. A person driving car at a constant speed of 15 m/s is approaching a vertical wall. The person notices a change of 40 Hz in the frequency of his car's horn upon reflection from the wall. The frequency of horn is _____ Hz.

Sol. (420)

$$f' = f_0 + 40$$

$$\Rightarrow f_0 \left(\frac{330+15}{330-15} \right) = f_0 + 40$$

$$\Rightarrow f_0 \times \frac{345}{315} = f_0 + 40$$

$$\Rightarrow f_0 \times \frac{30}{315} = 40$$

$$\Rightarrow f_0 = 40 \times \frac{315}{30} = 420 \text{ Hz}$$

60. A pole is vertically submerged in swimming pool, such that it gives a length of shadow 2.15 m within water when sunlight is incident at an angle of 30° with the surface of water. If swimming pool is filled to a height of 1.5 m, then the height of the pole above the water surface in centimeters is ($n_w = 4/3$) _____

Sol. (50)

$$\sin 60 = \frac{4}{3} \sin r$$

$$\Rightarrow \sin r = \frac{3}{4} \times \frac{\sqrt{3}}{2} = \frac{3\sqrt{3}}{8} \text{ ----- (i)}$$

$$\cos r = \sqrt{1 - \frac{27}{64}} = \frac{\sqrt{37}}{8} = 0.75$$

$$\Rightarrow \tan r = \sqrt{\frac{27}{37}}$$

$$\Rightarrow \frac{x}{1.5} = 0.85$$

$$\Rightarrow x = 0.85 \times 1.5 = 1.275 \text{ m}$$

$$\tan 30 = \frac{y}{2.15 - 1.275} = \frac{y}{0.875}$$

$$y = \frac{0.875}{1.732} = 0.50$$

So length of pole above water surface = 0.50m = 50cm

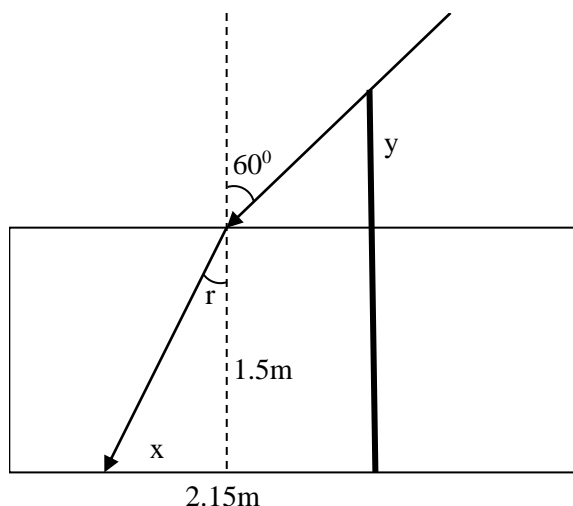

SECTION - A

61. Match List I with List II

List I (Natural Amino acid)	List II (One Letter Code)
(A) Arginine	(I) D
(B) Aspartic acid	(II) N
(C) Asparagine	(III) A
(D) Alanine	(IV) R

Choose the correct answer from the options given below:

- (1) (A) – III, (B) – I, (C) – II (D) –IV (2) (A) – IV, (B) – I, (C) – II (D) –III
 (3) (A) – IV, (B) – I, (C) – III (D) –II (4) (A) – I, (B) – III, (C) – IV (D) –II

Sol. 2

Natural Amino acid	One Letter Code
(i) Arginine	R
(ii) Aspartic acid	D
(iii) Asparagine	N
(iv) Alanine	A

62. Formation of which complex, among the following, is not a confirmatory test of Pb^{2+} ions

- (1) lead sulphate (2) lead nitrate (3) lead chromate (4) lead iodide

Sol. 2

∵ $Pb(NO_3)_2$ is a soluble colourless compound so it cannot be used in confirmatory test of Pb^{+2} ion.

63. The volume of 0.02 M aqueous HBr required to neutralize 10.0 mL of 0.01 M aqueous $Ba(OH)_2$ is (Assume complete neutralization)

- (1) 5.0 mL (2) 10.0 mL (3) 2.5 mL (4) 7.5 mL

Sol. 2

$$\begin{aligned} \text{m.eq. of HBr} &= \text{m.eq. of Ba(OH)}_2 \\ M_1 \times n_1 \times V_1(\text{mL}) &= M_2 \times n_2 \times V_2(\text{mL}) \\ 0.02 \times 1 \times V_1(\text{mL}) &= 0.02 \times 2 \times 10 \\ V_1(\text{mL}) &= 10 \text{ mL} \end{aligned}$$

64. Group-13 elements react with O_2 in amorphous form to form oxides of type M_2O_3 (M = element). Which among the following is the most basic oxide?

- (1) Al_2O_3 (2) Tl_2O_3 (3) Ga_2O_3 (4) B_2O_3

Sol. 2

As electropositive character increases basic character of oxide increases.

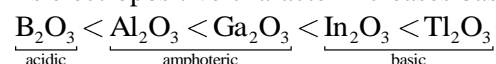

65. The IUPAC name of $K_3[Co(C_2O_4)_3]$ is -

- (1) Potassium tris(oxalate) cobaltate(III) (2) Potassium trioxalatocobalt(III)
 (3) Potassium trioxalatocobaltate(III) (4) Potassium tris(oxalate)cobalt(III)

Sol. 3

IUPAC name of $K_3[Co(C_2O_4)_3]$ is Potassium trioxalatocobaltate(III)

66. If the radius of the first orbit of hydrogen atom is a_0 , then de Broglie's wavelength of electron in 3rd orbit is

- (1) $\frac{\pi a_0}{6}$ (2) $\frac{\pi a_0}{3}$ (3) $6\pi a_0$ (4) $3\pi a_0$

Sol. 3

By De-Broglie principle

$$2\pi r = n\lambda$$

$$2\pi \times \frac{n^2}{Z} a_0 = n\lambda$$

$$2\pi \times \frac{n}{Z} a_0 = \lambda$$

$$\lambda = 2\pi \times \frac{3}{1} a_0 = 6\pi a_0$$

67. The group of chemicals used as pesticide is

- (1) Sodium chlorate, DDT, PAN (2) DDT, Aldrin
 (3) Aldrin, Sodium chlorate, Sodium arsinite (4) Dieldrin, Sodium arsinite, Tetrachlorothene

Sol. 2

(Fact base) DDT & Aldrin are used as pesticide

68. From the figure of column, chromatography given below, identify incorrect statements.

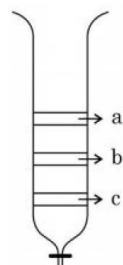

- A. Compound 'c' is more polar than 'a' and 'b'
 B. Compound 'a' is least polar
 C. Compound 'b' comes out of the column before 'c' and after 'a'
 D. Compound 'a' spends more time in the column

Choose the correct answer from the options given below:

- (1) A, B and D only (2) A, B and C only (3) B and D only (D) B, C and D only

Sol. 2

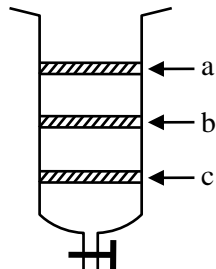

Adsorption of compound α Attraction
 α Polarity
 α Spend time in column
 $\alpha \frac{1}{\text{come out from column}}$

Order of polarity $\rightarrow a > b > c$

Come out from column order $\rightarrow c > b > a$

Spend time in column $\rightarrow a > b > c$

69. Ion having highest hydration enthalpy among the given alkaline earth metal ions is:

- (1) Be^{2+} (2) Ba^{2+} (3) Ca^{2+} (4) Sr^{2+}

Sol. 1

$$\text{Hydration enthalpy} \propto \frac{1}{\text{size}}$$

Down the group as size increases hydration enthalpy decreases

$$\text{Order: } \text{Be}^{2+} > \text{Mg}^{2+} > \text{Ca}^{2+} > \text{Sr}^{2+} > \text{Ba}^{2+}$$

70. The strongest acid from the following is

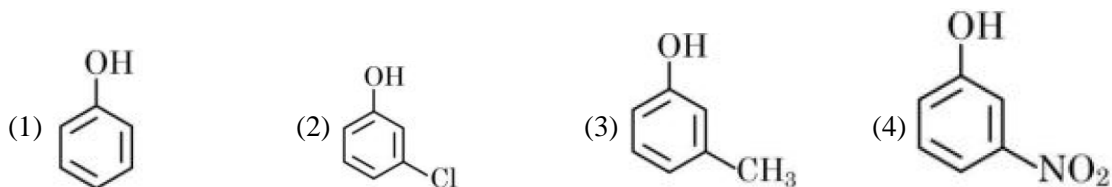

Sol. 4

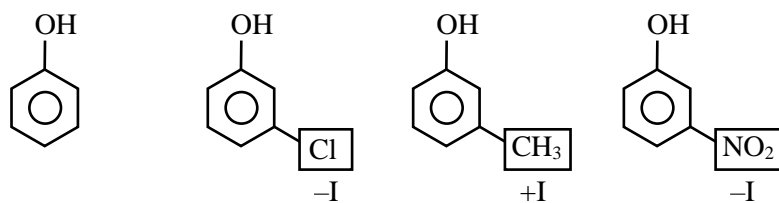

Since $-I$ of $-\text{NO}_2 > \text{Cl}$

So, most acidic will be (4)

71. In the following reaction, 'B' is

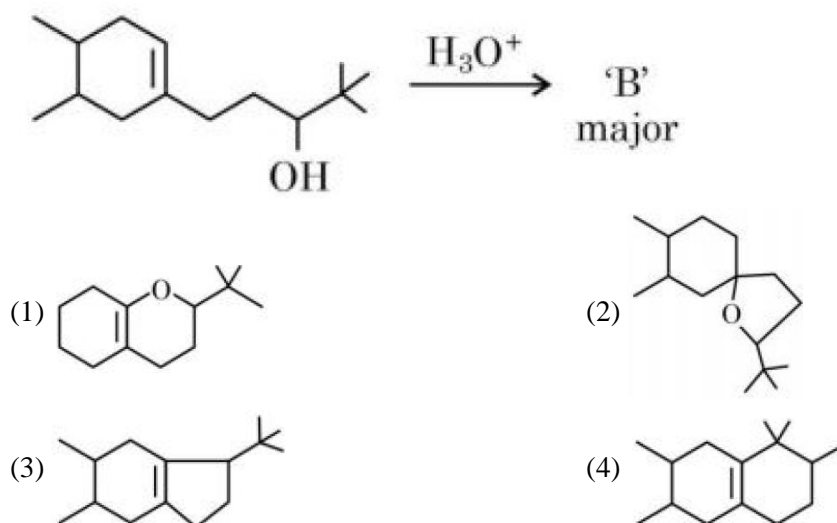

Sol. 4

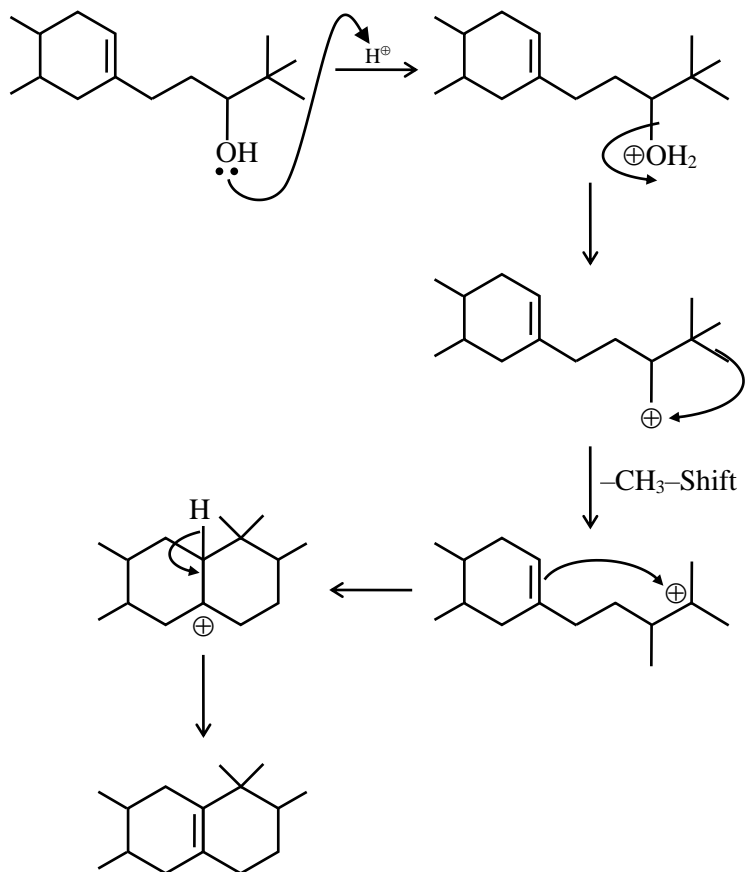

72. Structures of BeCl_2 in solid state, vapour phase and at very high temperature respectively are:

- (1) Polymeric, Dimeric, Monomeric (2) Dimeric, Polymeric, Monomeric
 (3) Monomeric, Dimeric, Polymeric (4) Polymeric, Monomeric, Dimeric

Sol. 1

In solid state BeCl_2 as polymer, in vapour state it form chloro-bridged dimer while above 1200K it is monomer.

73. Consider the following reaction that goes from A to B in three steps as shown below:

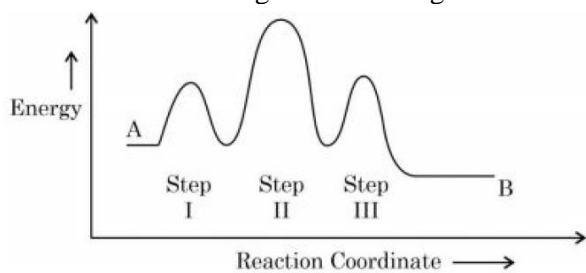

Choose the correct option

	Number of intermediates	Number of Activated complex	Rate determining step
(1)	2	3	II
(2)	3	2	II
(3)	2	3	III
(4)	2	3	I

Sol. 1

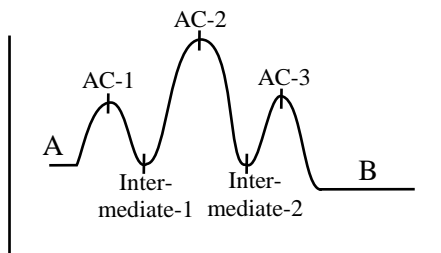

Number of Intermediate \rightarrow 2

Number of Activated complex \rightarrow 3

Rate determining step \rightarrow II

74. The product, which is not obtained during the electrolysis of brine solution is

- (1) HCl (2) NaOH (3) Cl₂ (4) H₂

Sol. 1

Brine solution (NaCl + H₂O)

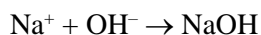
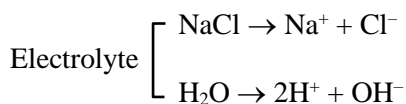

Answer 1 (HCl)

75. Which one of the following elements will remain as liquid inside pure boiling water?

- (1) Li (2) Ga (3) Cs (4) Br

Sol. 2

Li, Cs reacts vigorously with water.

Br₂ changes in vapour state in boiling water (BP = 58°C)

Ga reacts with water above 100°C (MP = 29°C, BP = 2400°C)

76. Given below are two statements: one is labelled as “**Assertion A**” and the other is labelled as “**Reason R**”

Assertion A: In the complex Ni(CO)₄ and Fe(CO)₅, the metals have zero oxidation state.

Reason R: Low oxidation states are found when a complex has ligands capable of π -donor character in addition to the σ -bonding.

In the light of the above statement, choose the most appropriate answer from the options given below

- (1) A is not correct but R is correct.
(2) A is correct but R is not correct
(3) Both A and R are correct and R is the correct explanation of A
(4) Both A and R are correct but R is NOT the correct explanation of A.

Sol. 2

Low oxidation state of metals can be stabilized by synergic bonding so ligand has to be π -acceptor.

77. Given below are two statements:

Statement I: Morphine is a narcotic analgesic. It helps in relieving pain without producing sleep.

Statement II: Morphine and its derivatives are obtained from opium poppy.

In the light of the above statements, choose the correct answer from the options given below

- (1) Statement I is true but statement II is false (2) Both statement I and statement II are true
 (3) Statement I is false but statement II is true (4) Both Statement I and Statement II are false

Sol. 3

Fact

Morphine →

- (i) Morphine is a narcotic analgesic, it help in relieving plan and producing sleep.
 (ii) Morphine and its derivatives are obtained from opium.

78. Find out the major product from the following reaction.

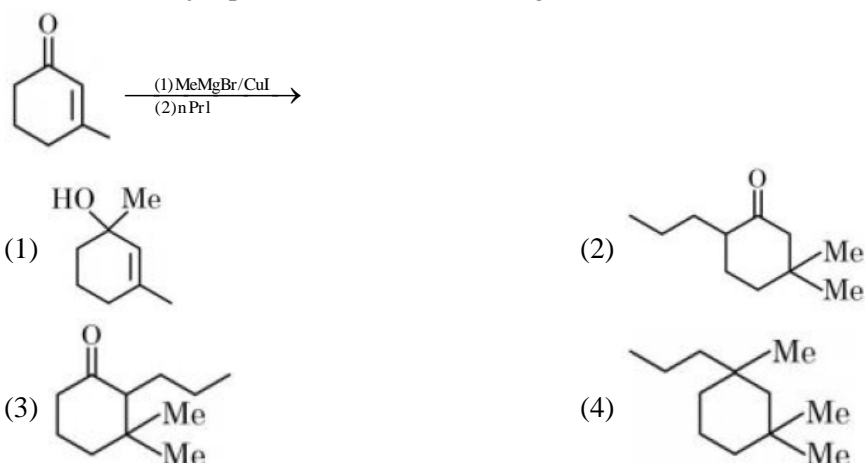

Sol. 3

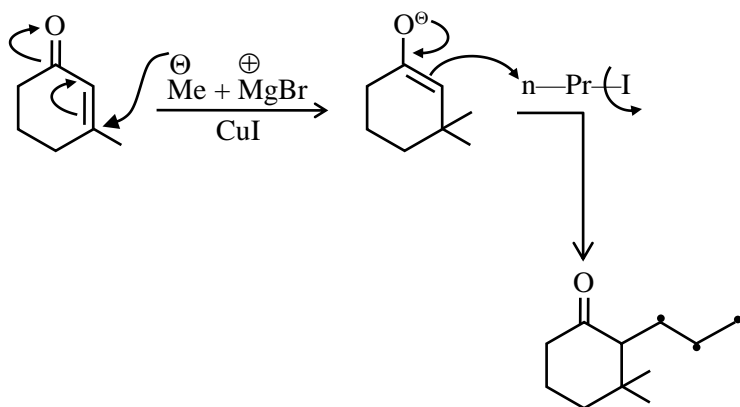

79. During the reaction of permanganate with thiosulphate, the change in oxidation of manganese occurs by value of 3. Identify which of the below medium will favour the reaction

- (1) aqueous neutral (2) aqueous acidic
 (3) both aqueous acidic and neutral (4) both aqueous acidic and faintly alkaline

Sol. 1

In neutral or weakly alkaline solution oxidation state of Mn changes by 3 unit

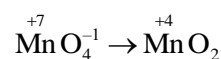

80. Element not present in Nessler's reagent is
 (1) K (2) N (3) I (4) Hg

Sol. 2
 Nessler reagent is- $K_2[HgI_4]$

SECTION - B

81. The standard reduction potentials at 298 K for the following half cells are given below:

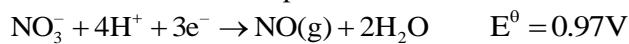

The number of metal(s) which will be oxidized by NO_3^- in aqueous solution is _____

Sol. 3
 Metal + $NO_3^- \rightarrow$ Metal Nitrate
 (V, Fe, Ag)
 ↓

Less value of reaction potential then 0.97 volt.
 Answer 3

82. Number of crystal system from the following where body centred unit cell can be found, is _____
 Cubic, tetragonal, orthorhombic, hexagonal, rhombohedral, monoclinic, triclinic

Sol. 3
 BCC present in \rightarrow Cubic, Tetragonal orthorhombic

83. Among the following the number of compounds which will give positive iodoform reaction is _____
 (a) 1-Phenylbutan-2-one (b) 2-Methylbutan-2-ol
 (c) 3-Methylbutan-2-ol (d) 1-Phenylethanol
 (e) 3,3-dimethylbutan-2-one (f) 1-Phenylpropan-2-ol

Sol. 4

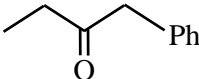
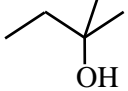
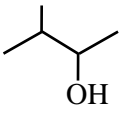
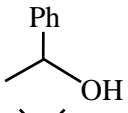
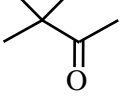
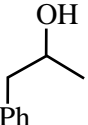
	Iodo form test
(a) 	-NO
(b) 	-NO
(c) 	-Yes
(d) 	-Yes
(e) 	-Yes
(f) 	-Yes

For carbonyl compound $\begin{array}{|c|} \hline C-CH_3 \\ \hline || \\ \hline O \\ \hline \end{array}$ for alcohol $\begin{array}{|c|} \hline CH-CH_3 \\ \hline | \\ \hline OH \\ \hline \end{array}$ should be present for iodoform test.

84. Number of isomeric aromatic amines with molecular formula $C_8H_{11}N$, which can be synthesized by Gabriel Phthalimide synthesis is _____

Sol. **6**

By Gabriel phthalimide synthesis \rightarrow i-amine is prepared
 $C_8H_{11}N \rightarrow$ Should be aromatic & i-amine

$$\begin{aligned} Du &= C + 1 - \frac{H - N}{2} \\ &= 8 + 1 - \frac{11 - 1}{2} \\ &= 9 - \frac{10}{2} = 9 - 5 = 4 \rightarrow \text{it means benzene ring} \end{aligned}$$

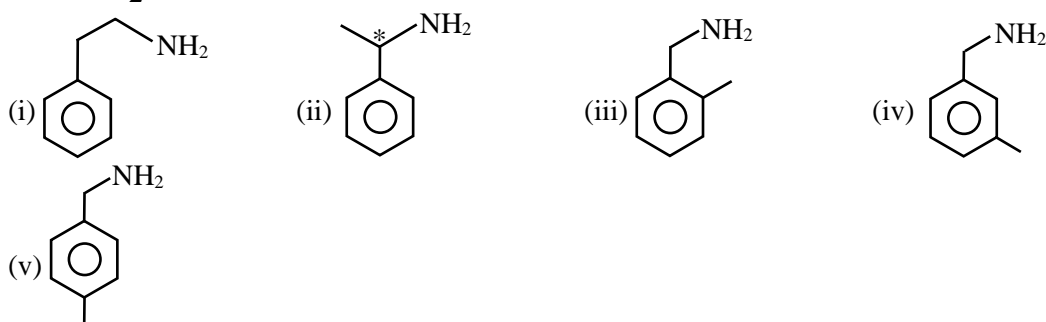

85. Consider the following pairs of solution which will be isotonic at the same temperature. The number of pairs of solutions is/are _____

- A. 1 M aq. NaCl and 2 M aq. Urea
 B. 1 M aq. $CaCl_2$ and 1.5 M aq. KCl
 C. 1.5 M aq. $AlCl_3$ and 2 M aq. Na_2SO_4
 D. 2.5 M aq. KCl and 1 M aq. $Al_2(SO_4)_3$

Sol. **4**

- A. 1 M aq. NaCl \Rightarrow 2 M aq. Ions
 2 M aq. Urea \Rightarrow 2 M aq. Urea } Isotonic
- B. 1 M aq. $CaCl_2 \Rightarrow$ 3 M aq. Ions
 1.5 M aq. KCl \Rightarrow 3 M aq. Ions } Isotonic
- C. 1.5 M aq. $AlCl_3 \Rightarrow$ 6 M aq. Ions
 2 M aq. $Na_2SO_4 \Rightarrow$ 6 M aq. Ions } Isotonic
- D. 2.5 M aq. KCl \Rightarrow 5 M aq. Ions
 1 M aq. $Al_2(SO_4)_3 \Rightarrow$ 5 M aq. Ions } Isotonic

86. The number of colloidal systems from the following, which will have 'liquid' as the dispersion medium, is _____

Gem stones, paints, smoke, cheese, milk, hair cream, insecticide sprays, froth, soap lather

Sol. **5**

Liquid dispersion medium

Paints, milk, hair cream, froth, soap lather

87. In an ice crystal, each water molecule is hydrogen bonded to neighbouring molecules.

Sol. 4

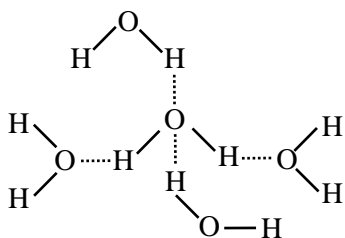

88. Consider the following data

$$\text{Heat of combustion of } \text{H}_2(\text{g}) = -241.8 \text{ kJ mol}^{-1}$$

$$\text{Heat of combustion of } \text{C}(\text{s}) = -393.5 \text{ kJ mol}^{-1}$$

$$\text{Heat of combustion of } \text{C}_2\text{H}_5\text{OH}(\text{l}) = -1234.7 \text{ kJ mol}^{-1}$$

The heat of formation of $\text{C}_2\text{H}_5\text{OH}(\text{l})$ is $(-)$ _____ kJ mol^{-1} (Nearest integer).

Sol. 278

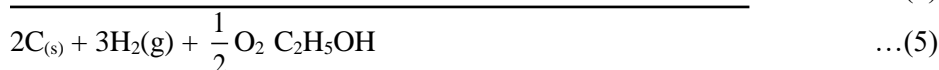
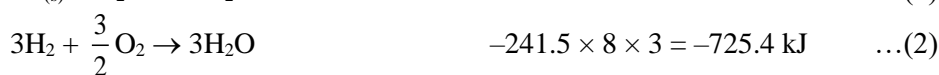

$$\begin{aligned} \text{eq (5)} &= \text{eq (1)} + \text{eq (2)} + \text{eq (4)} \\ &= (-787) + (-725.4) + (1234.7) \\ &= -277.7 = 278 \end{aligned}$$

89. The equilibrium composition for the reaction $\text{PCl}_3 + \text{Cl}_2 \rightleftharpoons \text{PCl}_5$ at 298 K is given below:

$$[\text{PCl}_3]_{\text{eq}} = 0.2 \text{ mol L}^{-1}, [\text{Cl}_2]_{\text{eq}} = 0.1 \text{ mol L}^{-1}, [\text{PCl}_5]_{\text{eq}} = 0.40 \text{ mol L}^{-1}$$

If 0.2 mol of Cl_2 is added at the same temperature, the equilibrium concentrations of PCl_5 is _____ $\times 10^{-2} \text{ mol L}^{-1}$

Given: K_c for the reaction at 298 K is 20

Sol. 49

NTA answer 48

$$K_c = \frac{[\text{PCl}_5]}{[\text{PCl}_3][\text{Cl}_2]} = \frac{0.4}{0.2 \times 0.1} = 20$$

	PCl_3	+	Cl_2	\rightleftharpoons	PCl_5
t_{eq1}	0.2 M		0.1 M		0.4 M
t_{eq2}	$0.2 - x$		$0.1 + 0.2 - x$		$0.4 + x$

$$K_c = 20 = \frac{0.4 + x}{(0.2 - x)(0.3 - x)}$$

After solving by quadratic equation. We can get value of x.

$$x = 0.086$$

$$\begin{aligned} [\text{PCl}_5] &= 0.4 + x \\ &= 0.4 + 0.086 \\ &= 0.486 = 48.6 \times 10^{-2} \end{aligned}$$

Ans. 49

90. The number of species having a square planar shape from the following is _____

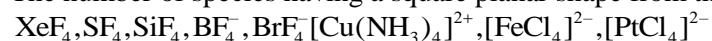

Sol. 4

$\text{XeF}_4, \text{BrF}_4^-, [\text{Cu}(\text{NH}_3)_4]^{2+}, [\text{PtCl}_4]^{2-}$ has square planar shape.